

Raymarine®

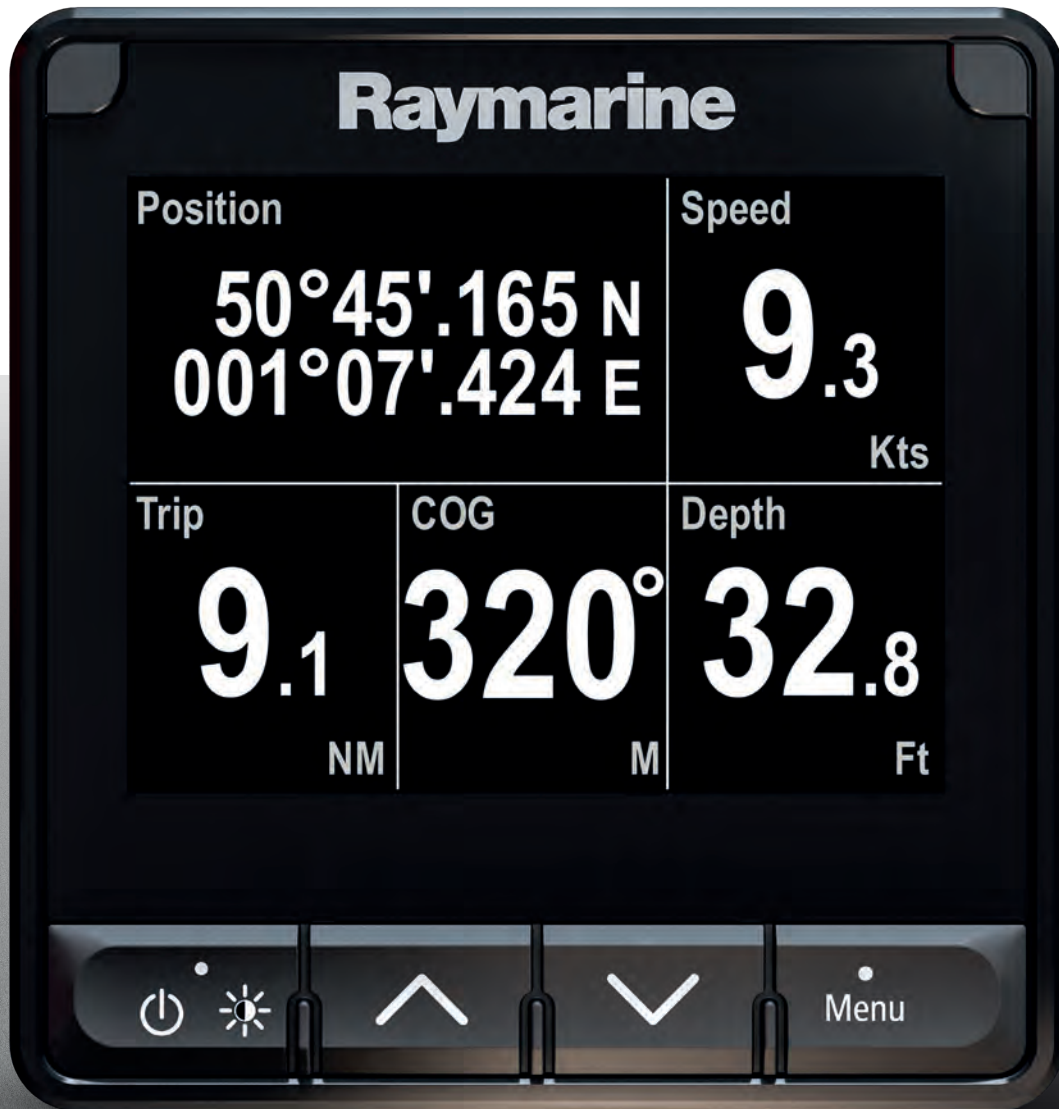

i70s INSTRUMENT

Installation instructions

English (en-US)
Date: 05-2021
Document number: 87420 (Rev 1)
© 2021 Raymarine UK Limited

Trademark and patents notice

Raymarine, Tacktick, Clear Pulse, Truzoom, SeaTalk, SeaTalk^{hs}, SeaTalkng, and **Micronet**, are registered or claimed trademarks of Raymarine Belgium.

FLIR, YachtSense, DockSense, LightHouse, DownVision, SideVision, RealVision, HyperVision, Dragonfly, Element, Quantum, Axiom, Instalert, Infrared Everywhere, The World's Sixth Sense and **ClearCruise** are registered or claimed trademarks of FLIR Systems, Inc.

All other trademarks, trade names, or company names referenced herein are used for identification only and are the property of their respective owners.

This product is protected by patents, design patents, patents pending, or design patents pending.

Fair Use Statement

You may print no more than three copies of this manual for your own use. You may not make any further copies or distribute or use the manual in any other way including without limitation exploiting the manual commercially or giving or selling copies to third parties.

Software updates



Check the Raymarine website for the latest software releases for your product.
www.raymarine.com/software

Product documentation



The latest versions of all English and translated documents are available to download in PDF format from the website: www.raymarine.com/manuals.
Please check the website to ensure you have the latest documentation.

Publication copyright

Copyright ©2021 Raymarine UK Ltd. All rights reserved. No parts of this material may be copied, translated, or transmitted (in any medium) without the prior written permission of Raymarine UK Ltd.

Contents

Chapter 1 Important information	9
TFT Displays	9
Water ingress	10
Disclaimer	10
Declaration of conformity.....	10
Product disposal	10
Warranty registration.....	10
IMO and SOLAS	10
Technical accuracy.....	11
Chapter 2 Document and product information.....	13
2.1 Document information.....	14
Product documentation	14
Document illustrations	14
2.2 Product overview	15
Controls	15
Parts supplied.....	16
Compatible transducers.....	17
Software updates.....	17
Typical systems	18
Chapter 3 Installation	21
3.1 Tools required	22
3.2 Selecting a location.....	22
Warnings and cautions	22
EMC installation guidelines.....	22
General location requirements	23
3.3 Product dimensions	24
3.4 Bezel removal	24
Removing the bezel.....	24
3.5 Removing the buttonpad.....	25
3.6 Mounting	26
Mounting diagram.....	26
Mounting instructions	26
Refitting the buttonpad.....	27
Chapter 4 Connections.....	29
4.1 General cabling guidance	30
Cable types and length.....	30
Cable routing	30
Strain relief.....	30
Cable shielding	30

4.2 Connections overview	31
Connecting SeaTalkng® cables	31
SeaTalkng® product loading.....	31
4.3 Cable ferrite installation.....	32
4.4 SeaTalkng® power supply.....	32
SeaTalkng® power connection point	32
In-line fuse and thermal breaker ratings	33
SeaTalkng® system loading	33
Power distribution — SeaTalkng®	34
4.5 NMEA 2000 connection.....	37
4.6 SeaTalk connection	37
4.7 Transducer connections	38
iTC-5 connection	38
Transducer pod connection.....	39
Chapter 5 Maintenance	43
5.1 Service and maintenance.....	44
5.2 Routine equipment checks	44
5.3 Product cleaning	44
5.4 Cleaning the display case	44
5.5 Cleaning the display screen	44
Transducer cleaning	44
5.6 Cleaning the sun cover	45
Chapter 6 Troubleshooting	47
6.1 Troubleshooting	48
6.2 Power up troubleshooting	48
Performing a Factory Reset	48
6.3 System data troubleshooting.....	49
6.4 Miscellaneous troubleshooting	49
Chapter 7 Technical support.....	51
7.1 Raymarine product support and servicing	52
7.2 Viewing product information.....	53
Chapter 8 Technical specification.....	55
8.1 Technical specification	56
Chapter 9 Spares and accessories	57
9.1 Spares and Accessories.....	58
9.2 Smart transducers	58
9.3 Instrument Depth, Speed and Temperature (DST) transducers.....	59
9.4 Instrument Depth transducers	59
9.5 Instrument Speed and Temperature transducers.....	60
9.6 Instrument Wind Vane transducer	61
9.7 Instrument Rotavecta transducer	62

9.8 Other transducers	62
9.9 SeaTalkng [®] cables and accessories.....	63
Appendix A Supported NMEA 2000 PGN list	69

Chapter 1: Important information



Warning: Product installation and operation

- This product must be installed and operated in accordance with the instructions provided. Failure to do so could result in personal injury, damage to your vessel and/or poor product performance.
- Raymarine highly recommends certified installation by a Raymarine approved installer. A certified installation qualifies for enhanced product warranty benefits. Register your warranty on the Raymarine website: www.raymarine.com/warranty



Warning: Potential ignition source

This product is NOT approved for use in hazardous/flammable atmospheres. Do NOT install in a hazardous/flammable atmosphere (such as in an engine room or near fuel tanks).



Warning: Product grounding

Before applying power to this product, ensure it has been correctly grounded, in accordance with the instructions provided.



Warning: Positive ground systems

Do not connect this unit to a system which has positive grounding.



Warning: Switch off power supply

Ensure the vessel's power supply is switched OFF before starting to install this product. Do NOT connect or disconnect equipment with the power switched on, unless instructed in this document.



Warning: Power supply voltage

Connecting this product to a voltage supply greater than the specified maximum rating may cause permanent damage to the unit. Refer to the product's information label for the correct voltage.

Caution: Power supply protection

When installing this product ensure the power source is adequately protected by means of a suitably-rated fuse or thermal circuit breaker.

Caution: Sun covers

- If your product is supplied with a sun cover, to protect against the damaging effects of ultraviolet (UV) light, always fit the sun cover when the product is not in use.
- To avoid potential loss, sun covers must be removed when travelling at high speed, whether in water or when the vessel is being towed.

TFT Displays

The colors of the display may seem to vary when viewed against a colored background or in colored light. This is a perfectly normal effect that can be seen with all color Thin Film Transistor (TFT) displays.

Water ingress

Water ingress disclaimer

Although the waterproof rating capacity of this product meets the stated water ingress protection standard (refer to the product's *Technical Specification*), water intrusion and subsequent equipment failure may occur if the product is subjected to high-pressure washing. Raymarine will not warrant products subjected to high-pressure washing.

Disclaimer

Raymarine does not warrant that this product is error-free or that it is compatible with products manufactured by any person or entity other than Raymarine.

Raymarine is not responsible for damages or injuries caused by your use or inability to use the product, by the interaction of the product with products manufactured by others, or by errors in information utilized by the product supplied by third parties.

Declaration of conformity

FLIR Belgium BVBA declares that the following products are in compliance with the EMC Directive 2014/30/EU:

- i70s multifunction instrument display, part number E70327

The original Declaration of Conformity certificate may be viewed on the relevant product page at www.raymarine.com/manuals.

Product disposal

Dispose of this product in accordance with the WEEE Directive.

The Waste Electrical and Electronic Equipment (WEEE) Directive requires the recycling of waste electrical and electronic equipment which contains materials, components and substances that may be hazardous and present a risk to human health and the environment when WEEE is not handled correctly.

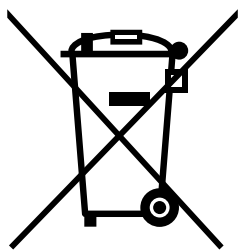

Equipment marked with the crossed-out wheeled bin symbol indicates that the equipment should not be disposed of in unsorted household waste.

Local authorities in many regions have established collection schemes under which residents can dispose of waste electrical and electronic equipment at a recycling center or other collection point.

For more information about suitable collection points for waste electrical and electronic equipment in your region, refer to the Raymarine website: www.raymarine.eu/recycling.



Warranty registration

To register your Raymarine product ownership, please visit www.raymarine.com and register online.

It is important that you register your product to receive full warranty benefits. Your unit package includes a bar code label indicating the serial number of the unit. You will need this serial number when registering your product online. You should retain the label for future reference.

IMO and SOLAS

The equipment described within this document is intended for use on leisure marine boats and workboats NOT covered by International Maritime Organization (IMO) and Safety of Life at Sea (SOLAS) Carriage Regulations.

Technical accuracy

To the best of our knowledge, the information in this document was correct at the time it was produced. However, Raymarine cannot accept liability for any inaccuracies or omissions it may contain. In addition, our policy of continuous product improvement may change specifications without notice. As a result, Raymarine cannot accept liability for any differences between the product and this document. Please check the Raymarine website (www.raymarine.com) to ensure you have the most up-to-date version(s) of the documentation for your product.

Chapter 2: Document and product information

Chapter contents

- [2.1 Document information on page 14](#)
- [2.2 Product overview on page 15](#)

2.1 Document information

This document contains important information related to the installation of your Raymarine product. The document includes information to help you:

- plan your installation and ensure you have all the necessary equipment;
- install and connect your product as part of a wider system of connected marine electronics;
- troubleshoot problems and obtain technical support if required.

This and other Raymarine product documents are available to download in PDF format from www.raymarine.com/manuals.

Product documentation

The following documentation is applicable to your product:

This and other Raymarine product documents are available to download in PDF format from www.raymarine.com.

i70s documentation:

- **87420** — i70s Multifunction Instrument Display Installation Instructions (This document)
- **81401** — i70 / i70s Operation Instructions
- **87260** — i70s Mounting Template

Additional documentation:

- **81300** — SeaTalkng[®] Reference Manual
- **87138** — iTC-5 Installation Instructions

User manuals Print Shop

Raymarine provides a Print Shop service, enabling you to purchase a high-quality, professionally-printed manual for your Raymarine product.

Printed manuals are ideal for keeping onboard your vessel, as a useful source of reference whenever you need assistance with your Raymarine product.

Visit <http://www.raymarine.co.uk/view/?id=5175> to order a printed manual, delivered directly to your door.

For further information about the Print Shop, please visit the Print Shop FAQ pages: <http://www.raymarine.co.uk/view/?id=5751>.

Note:

- Accepted methods of payment for printed manuals are credit cards and PayPal.
- Printed manuals can be shipped worldwide.
- Further manuals will be added to the Print Shop over the coming months for both new and legacy products.
- Raymarine user manuals are also available to download free-of-charge from the Raymarine website, in the popular PDF format. These PDF files can be viewed on a PC / laptop, tablet, smartphone, or on the latest generation of Raymarine multifunction displays.

Multifunction instrument display operation instructions

For operation instructions please refer to the i70 / i70s operation instructions.



The i70 / i70s operation instructions (81401) can be downloaded from the Raymarine website: www.raymarine.com/manuals. Please check the website to ensure you have the latest documentation.

Document illustrations

Your product and if applicable, its user interface may differ slightly from that shown in the illustrations in this document, depending on product variant and date of manufacture.

All images are provided for illustration purposes only.

2.2 Product overview

The i70s (E70327) is a multifunctional instrument display. In conjunction with compatible instrument transducers and an iTC-5, the i70s provides a detailed view of environmental, navigational and vessel data.

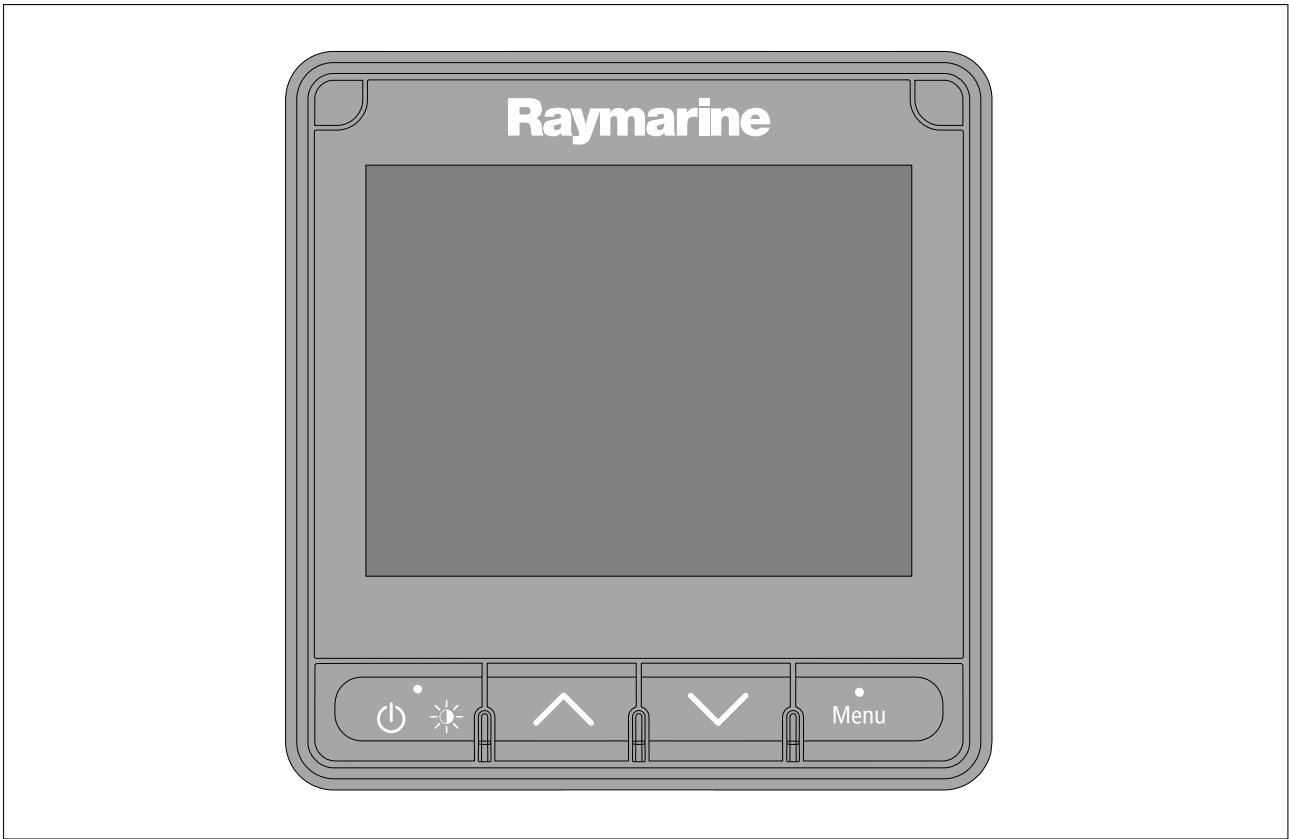

The i70s (E70327) has the following features:

- 4.1" high brightness color LCD with wide viewing angles
- SeaTalkng[®], NMEA 2000 and SeaTalk[®] compatible
- All weather optically bonded LCD
- Large clear characters (up to 43 mm / 1.7 in) for easy reading in any conditions
- Easy to use LightHouse™ operating system
- AIS repeater and display of AIS targets
- Data views include: Wind, Speed, Depth, Tridata, Engine, Environment, Fuel and Navigation
- 12 V dc operation
- Low power consumption
- Waterproof to IPx6 and IPx7

Controls

Use the buttons to operate the display. Each button has multiple functions.

Note:

The i70s is pictured below. The i70 and i70s have the same control buttons.

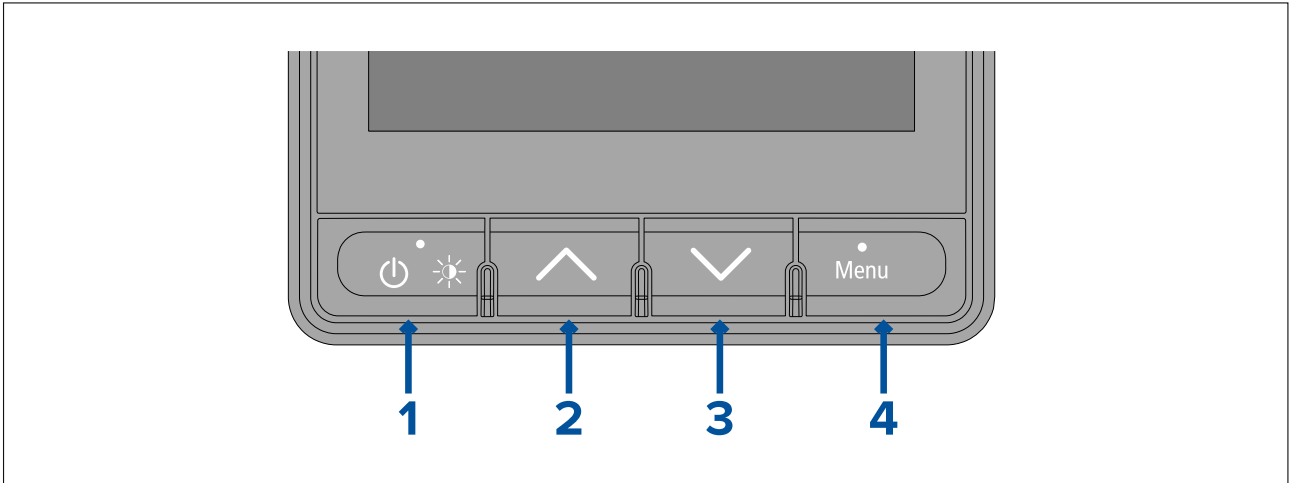

1. **Power**

- Power on
- Power off
- Open Brightness page
- Cancel
- Back

2. **Up**

- Next Favorite page
- Move up in menu
- Increase a numeric value

3. **Down**

- Previous Favorite page
- Move down in menu
- Decrease a numeric value

4. **Menu**

- Open menu
- Select menu item
- OK
- Save

Parts supplied

The following parts are supplied with your product.

Unpack your product carefully to prevent damage or loss of parts, check the box contents against the list above. Retain the packaging and documentation for future reference.

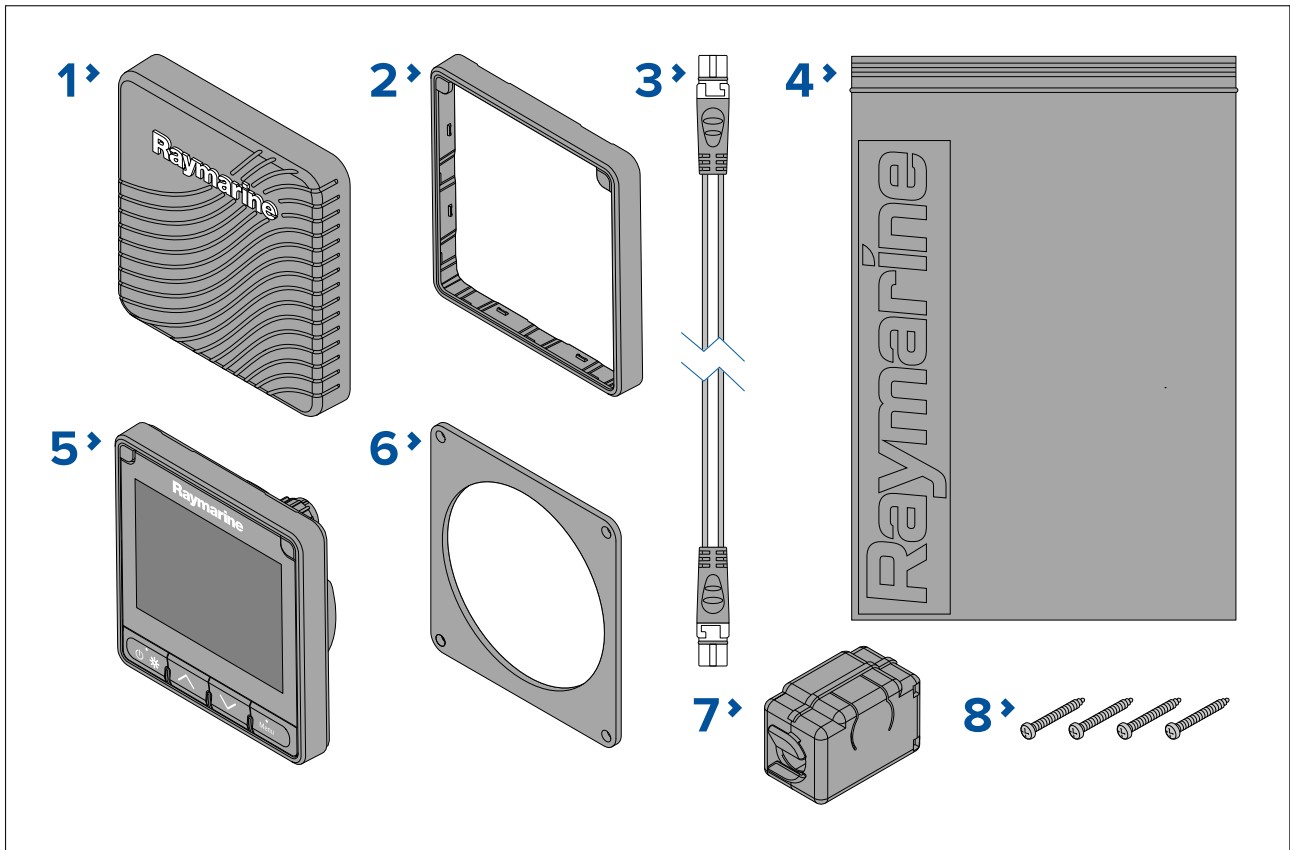

1. Suncover (Part No.: A80357)
2. Alternative gunmetal bezel (Part No.: A80354)
3. SeaTalkng® spur cable 400 mm (15.7 in) (Part No.: A06038)
4. Documentation pack
5. i70s instrument display (supplied with buttonpad and black bezel, Part No.: A80353 fitted)
6. Panel seal gasket
7. Cable suppression ferrite
8. 4 x M3x16 pan head pozi mounting screws

Compatible transducers

For a list of compatible transducers please refer to [Chapter 9 Spares and accessories](#).

Software updates

The software running on the product can be updated.

- Raymarine periodically releases software updates to improve product performance and add new features.
- The software on many products can be updated using a connected and compatible multifunction display (MFD).
- Refer to www.raymarine.com/software/ for the latest software updates and the software update procedure for your specific product.

Important:

- To prevent potential software-related issues with your product, always follow the relevant update instructions carefully and in the sequence provided.
- If in doubt as to the correct procedure for updating your product software, refer to your dealer or Raymarine technical support.

Caution: Installing software updates

- The software update process is carried out at your own risk. Before initiating the update process ensure you have backed up any important files.
- Ensure that the unit has a reliable power supply and that the update process is not interrupted.
- Damage caused by an incomplete update is not covered by Raymarine warranty.
- By downloading the software update package, you agree to these terms.

Typical systems

The following illustrations show example i70s SeaTalkng® systems .

Example: Simple environmental data system

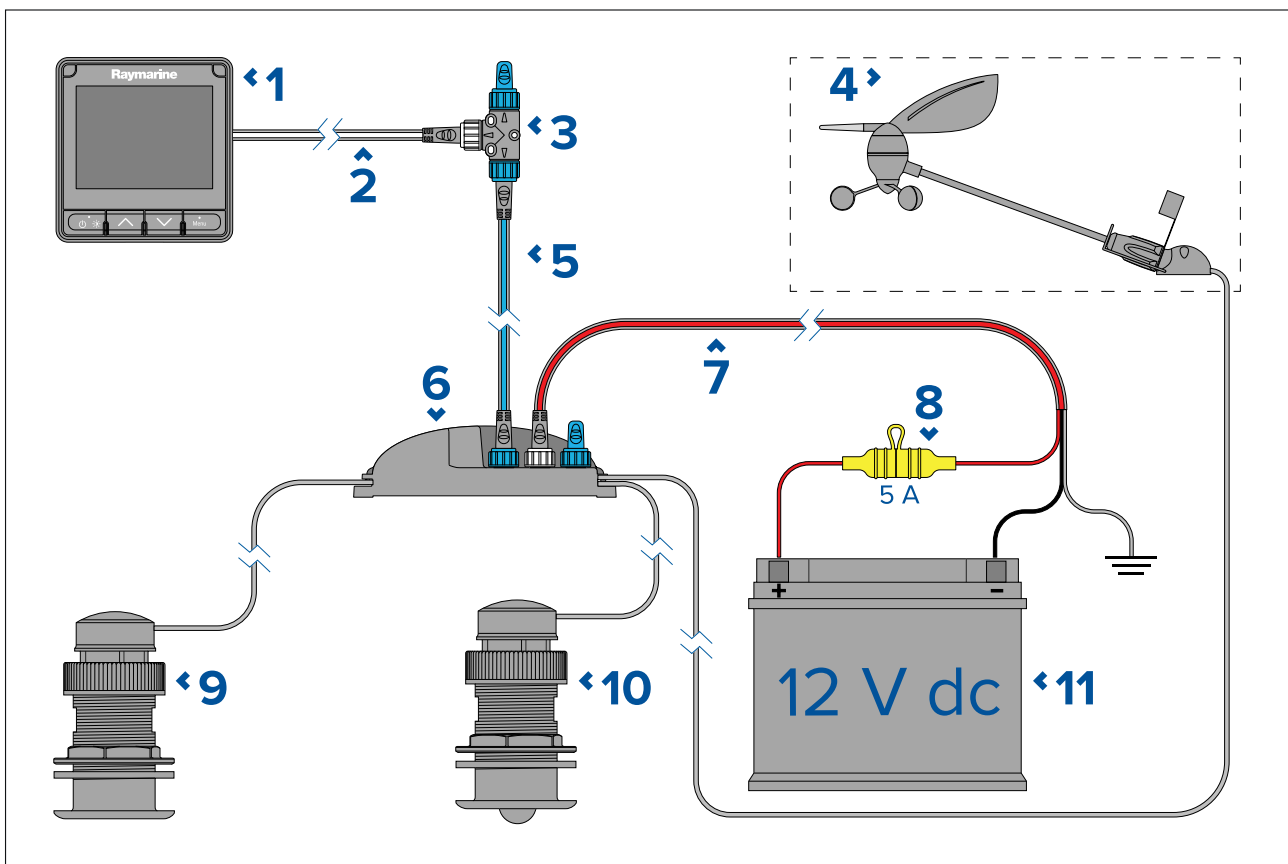

1. i70s Instrument display.
2. SeaTalkng® spur cable.
3. SeaTalkng® T-piece connector with Terminator fitted.
4. Wind transducer (Analog).
5. SeaTalkng® backbone cable.
6. iTC-5 with terminator fitted.
7. SeaTalkng® power cable.
8. 5 amp fuse in waterproof fuse holder.
9. Depth transducer (Analog).
10. Speed / Temperature transducer (Analog).
11. 12 V dc power supply.

Example: Expanded system

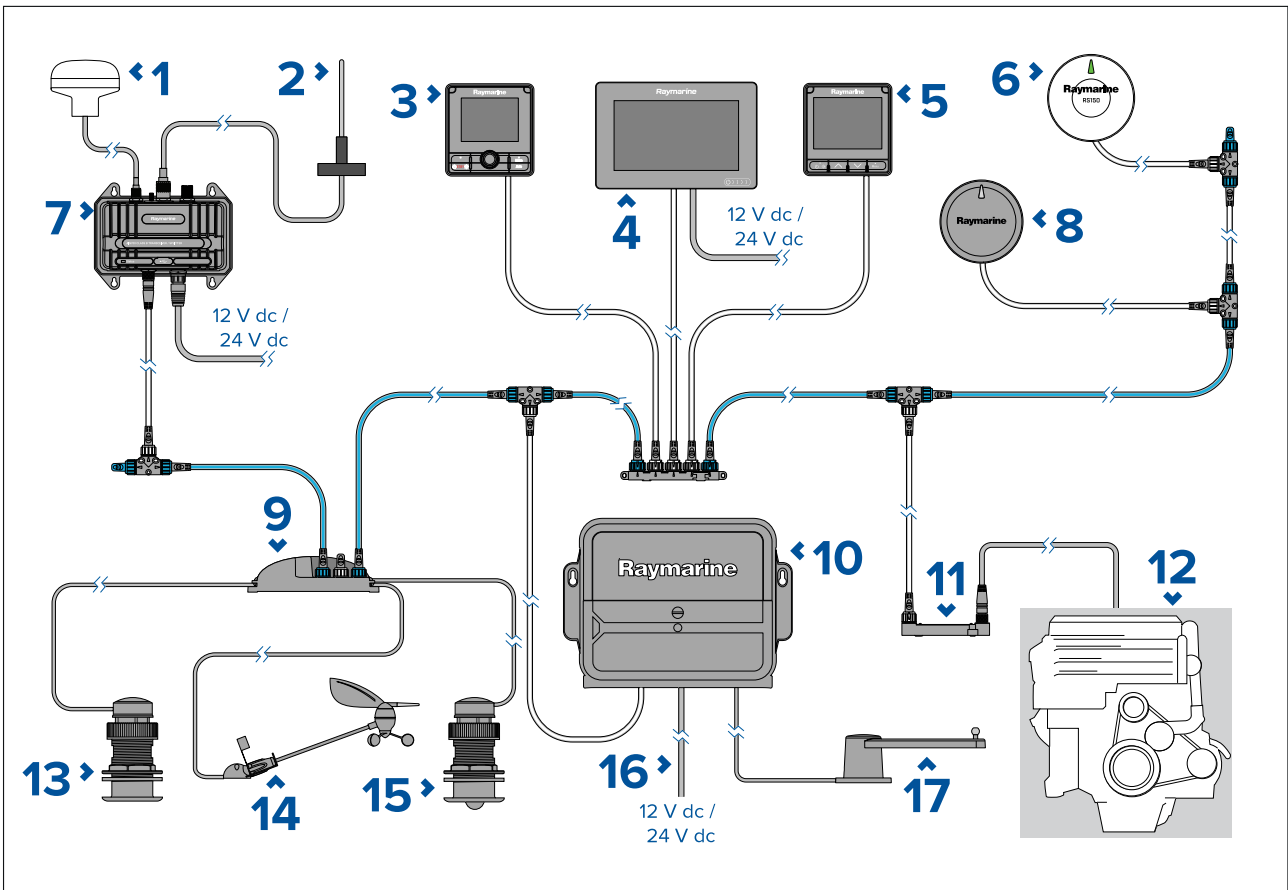

1. AIS dedicated GNSS (GPS) receiver
2. VHF antenna
3. SeaTalkng[®] pilot controller (e.g.: p70Rs)
4. MFD (e.g.: Axiom™ 7+)
5. i70s instrument display
6. GNSS (GPS) receiver (e.g.: RS150)
7. AIS receiver / transceiver (e.g.: AIS700)
8. Evolution autopilot (e.g.: EV-1)
9. iTC-5
10. Autopilot control unit (e.g.: ACU-400)
11. ECI-100

Note: Depending on engine type, it may be possible to connect the engine system directly to the SeaTalkng[®] backbone using a SeaTalkng[®] to DeviceNet adaptor cable. However the data available will be restricted to supported, standard NMEA 2000 data only.

12. Vessel / Engine systems
13. Depth transducer (Analog)
14. Wind transducer (Analog)
15. Speed / Temperature transducer (Analog)
16. 12 V dc / 24 V dc power supply (supplying 12 V dc to the SeaTalkng[®] backbone via the ACU.
17. Rudder reference transducer

Chapter 3: Installation

Chapter contents

- 3.1 Tools required on page 22
- 3.2 Selecting a location on page 22
- 3.3 Product dimensions on page 24
- 3.4 Bezel removal on page 24
- 3.5 Removing the buttonpad on page 25
- 3.6 Mounting on page 26

3.1 Tools required

The following tools are required to install your product.

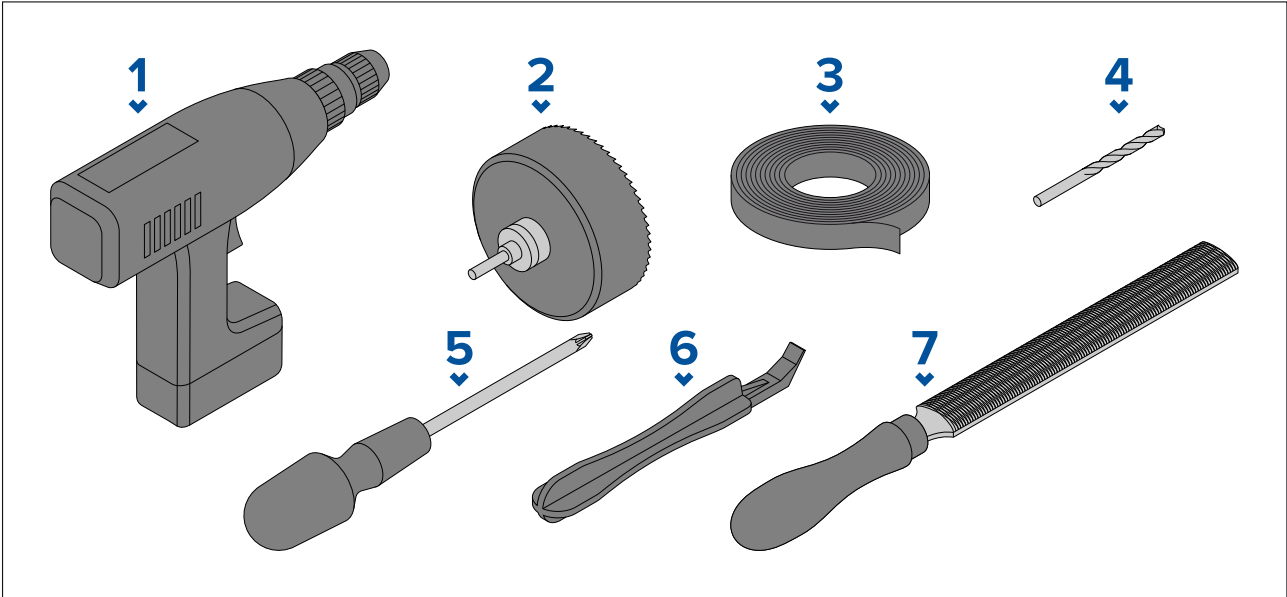

1. Power drill
2. 92 mm (3 5/8 in) Hole cutter
3. Adhesive tape
4. Drill bit of appropriate size for mounting fixings⁽¹⁾
5. Pozi drive screwdriver
6. Plastic pry tool
7. File

Note:

(1) Drill bit size is dependent on the thickness and type of material that the product is to be mounted on.

3.2 Selecting a location

Warnings and cautions

Important: Before proceeding, ensure that you have read and understood the warnings and cautions provided in the [Chapter 1 Important information](#) section of this document.

EMC installation guidelines

Raymarine equipment and accessories conform to the appropriate Electromagnetic Compatibility (EMC) regulations, to minimize electromagnetic interference between equipment and minimize the effect such interference could have on the performance of your system

Correct installation is required to ensure that EMC performance is not compromised.

Note: In areas of extreme EMC interference, some slight interference may be noticed on the product. Where this occurs the product and the source of the interference should be separated by a greater distance.

For **optimum** EMC performance we recommend that wherever possible:

- Raymarine equipment and cables connected to it are:
 - At least 1 m (3.3 ft) from any equipment transmitting or cables carrying radio signals e.g. VHF radios, cables and antennas. In the case of SSB radios, the distance should be increased to 2 m (6.6 ft).
 - More than 2 m (6.6 ft) from the path of a radar beam. A radar beam can normally be assumed to spread 20 degrees above and below the radiating element.

- The product is supplied from a separate battery from that used for engine start. This is important to prevent erratic behavior and data loss which can occur if the engine start does not have a separate battery.
- Raymarine specified cables are used.
- Cables are not cut or extended, unless doing so is detailed in the installation manual.

Note:

Where constraints on the installation prevent any of the above recommendations, always ensure the maximum possible separation between different items of electrical equipment, to provide the best conditions for EMC performance throughout the installation.

General location requirements

Below are important requirements that need to be considered when choosing a suitable location to install your product.

The product is suitable for mounting above or below decks.

The product should be mounted in a location where it will be:

- protected from physical damage and excessive vibration.
- well ventilated and away from heat sources.
- away from any potential ignition source such as an engine room, near fuel tanks or a gas locker.
- easily accessible for operations.

When choosing a location for the product, consider the following to ensure reliable and trouble-free operation:

- Access — there must be sufficient space to enable cable connections and to avoid tight cable bends.
- Electrical interference — the product should be mounted far enough away from any equipment that may cause interference such as engines, motors, generators, radio transmitters / receivers and cables carrying high power.
- Magnetic compass — refer to the *Compass safe distance* section in this document for advice on maintaining a suitable distance between this product and any compasses on your vessel.
- Mounting surface — ensure the product is adequately supported on a secure surface. Refer to the weight information provided in the *Technical specification* for this product and ensure that the intended mounting surface is suitable for bearing the product weight. Do NOT mount units or cut holes in places which may damage the structure of the vessel.

Compass safe distance

To prevent potential interference with the vessel's magnetic compasses, ensure an adequate distance is maintained from the product.

When choosing a suitable location for the product you should aim to maintain the maximum possible distance from any compasses. Typically this distance should be at least 1 m (3.3 ft) in all directions. However for some smaller vessels it may not be possible to locate the product this far away from a compass. In this situation, when choosing the installation location for your product, ensure that the compass is not affected by the product when it is in a powered state.

Viewing angle considerations

As display contrast and color are affected by the viewing angle, It is recommended that you temporarily power up the display, prior to installation, to enable you to best judge which location provides the optimum viewing angle.

For the viewing angles for your product refer to [p.55 — Technical specification](#)

3.3 Product dimensions

Product dimensions are shown below.

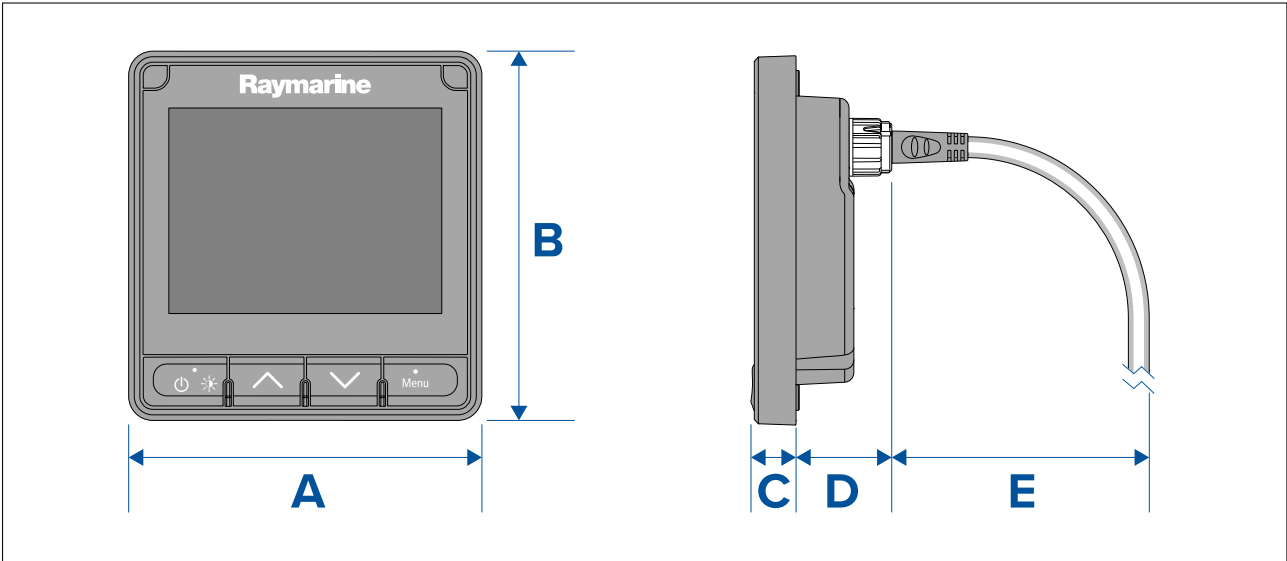

- **A:** 110 mm (4.33 in)
- **B:** 115 mm (4.53 in)
- **C:** 14.05 mm (0.55 in)
- **D:** 29.80 mm (1.17 in)
- **E:** 80.00 mm (3.15 in)

3.4 Bezel removal

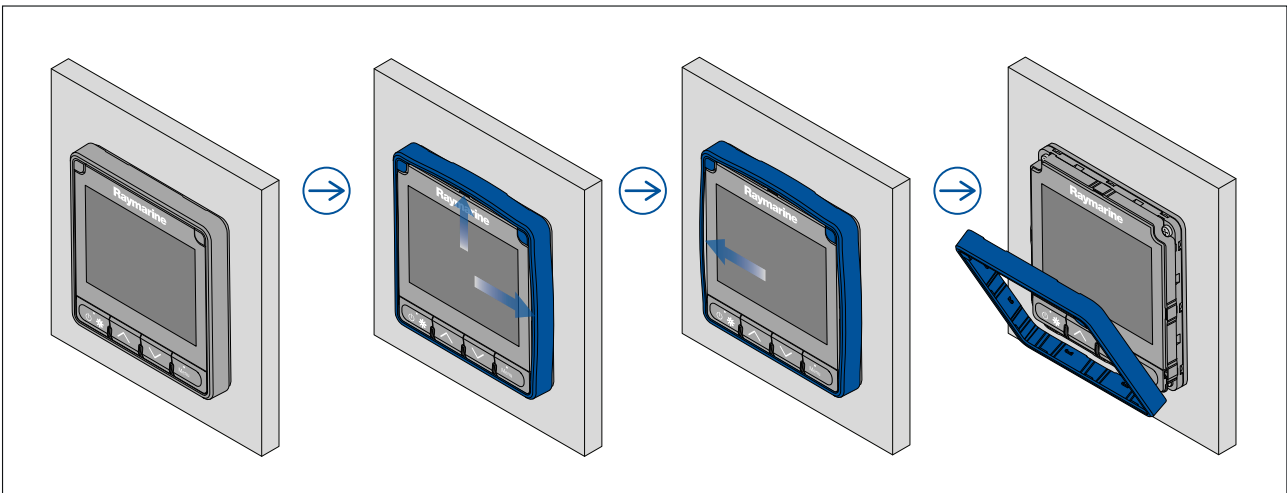

Removing the bezel

Note:

Take care when removing the bezel. Only use a plastic pry tool (not supplied) to lever the bezel, attempting to use a metal tool may cause damage.

1. Using a plastic pry tool and your fingers pry the bezel away from the display at the top and on one side.

You should hear a click as each side is released.

2. Now pry the bezel away from the display on the opposite side.
The bezel can now be pulled away from the display.

3.5 Removing the buttonpad

To remove the buttonpad from the display follow the steps below.

Important:

Ensure that you do not bend the buttonpad during removal as this may prevent the buttonpad from fitting correctly.

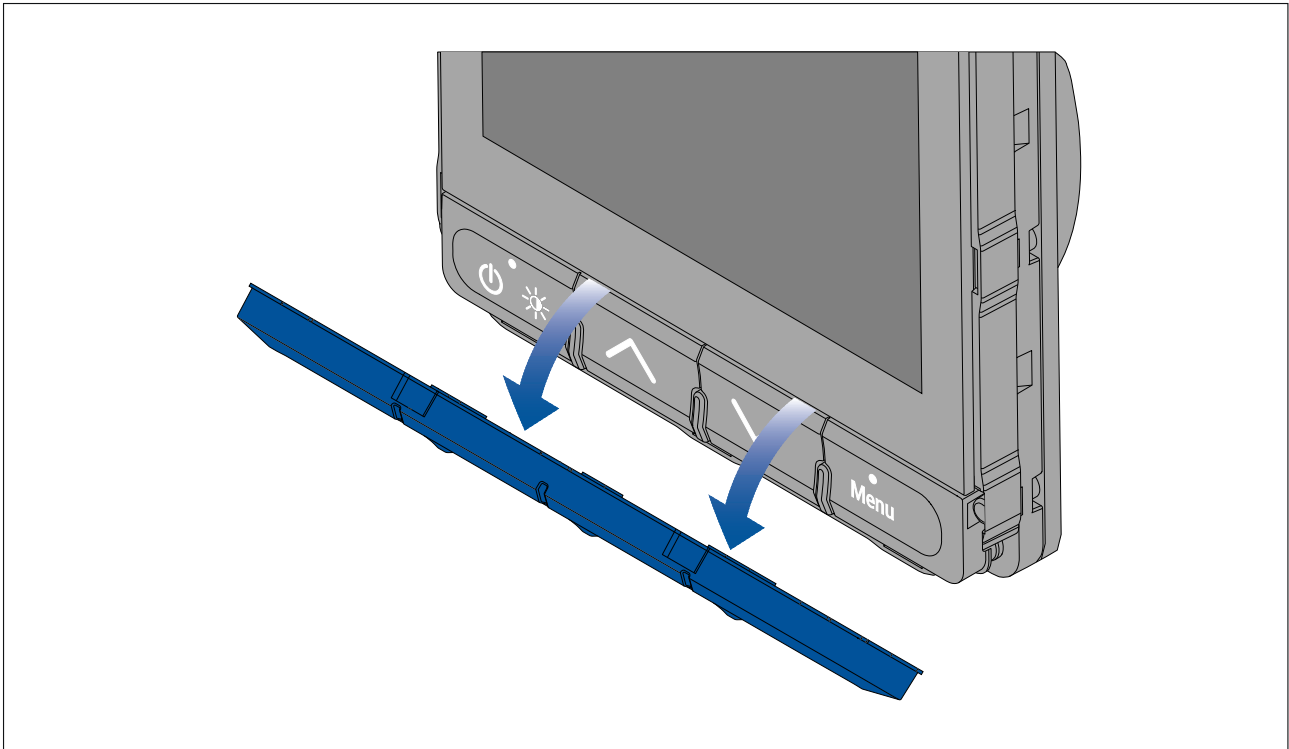

1. Remove the bezel following the instruction found here: [p.24 – Removing the bezel](#).
2. Using your fingers, grip the top edge of the buttonpad and pull it down and away from the unit.

3.6 Mounting

Mounting diagram

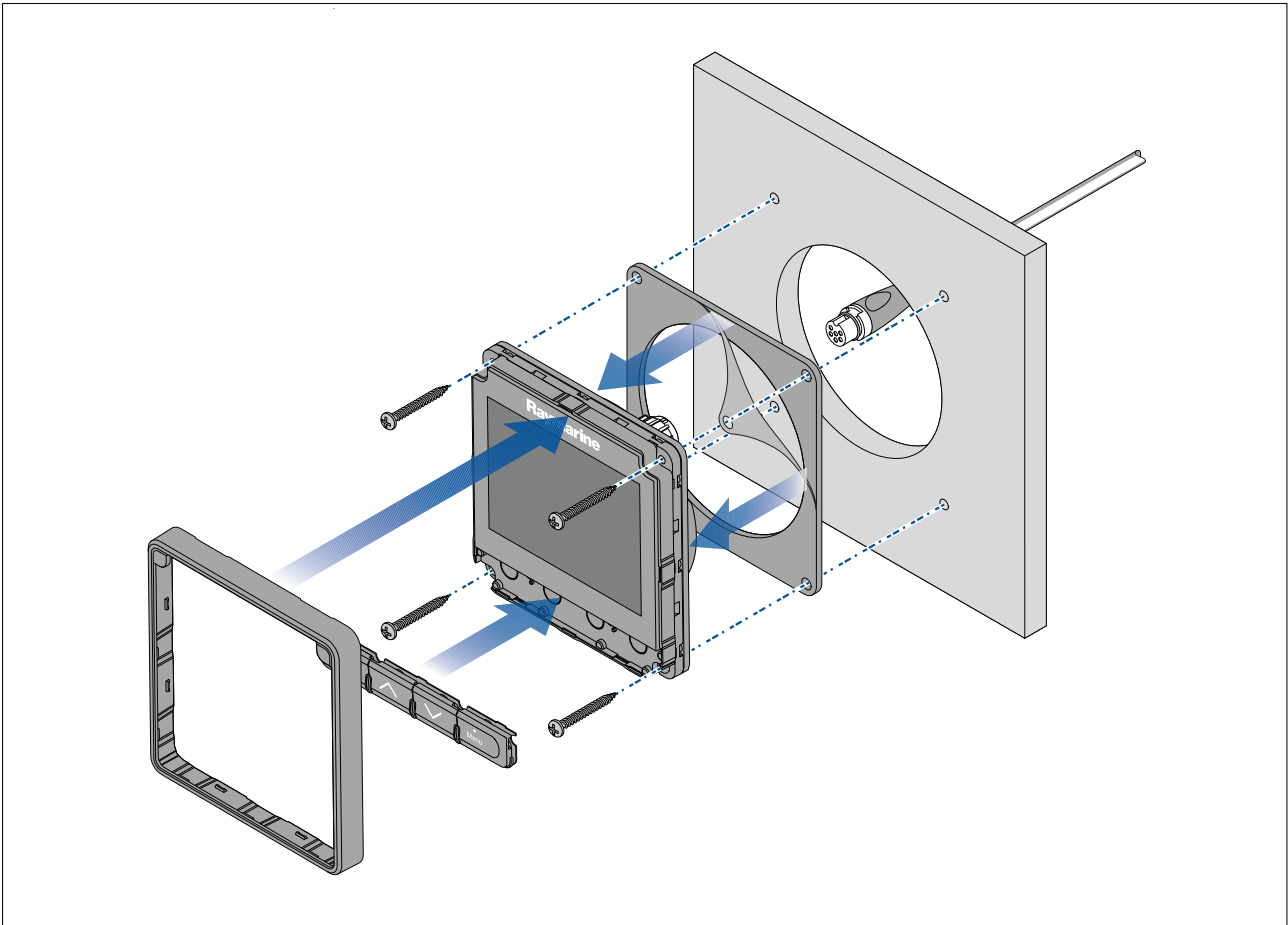

Mounting instructions

1. Ensure the selected location meets the location requirements found here:
[p.23 – General location requirements](#)
2. Check the selected location for the display, a clear, flat area with suitable clearance behind the panel is required.
3. Remove the bezel and buttonpad from the display.
4. Fix the supplied mounting template to the selected location, using self adhesive tape.
5. Drill the cut out hole using a 92 mm (3 5/8") hole cutter.

Alternatively, use small drill bit to make pilot holes in each corner of the cut out area and then use a jigsaw to cut along the inside edge of the cut out line.

6. Ensure that the display fits into the removed area.
7. File around any rough edges.
8. Drill the fixing holes as indicated on the mounting template.
9. Peel the backing off of the panel mounting gasket and place the adhesive side of the gasket onto the back of the display and press firmly onto the flange.
10. Connect the SeaTalkng[®] cable.
11. Position the display in place and secure using the fixings provided.
12. Refit buttonpad and bezel.

Note:

- Drill bit, tap size and tightening torques are dependant upon the material type and thickness of the mounting surface.
- The supplied gasket provides a seal between the unit and a suitably flat and stiff mounting surface or binnacle. The gasket should be used in all installations. If the mounting surface or binnacle is not entirely flat and stiff or has a rough surface finish ,it may also be necessary to use a marine-grade sealant.

Refitting the buttonpad

The buttonpad is held in place by tabs, located on the top and bottom edge of the buttonpad. To refit the buttonpad correctly all of the tabs must be engaged.

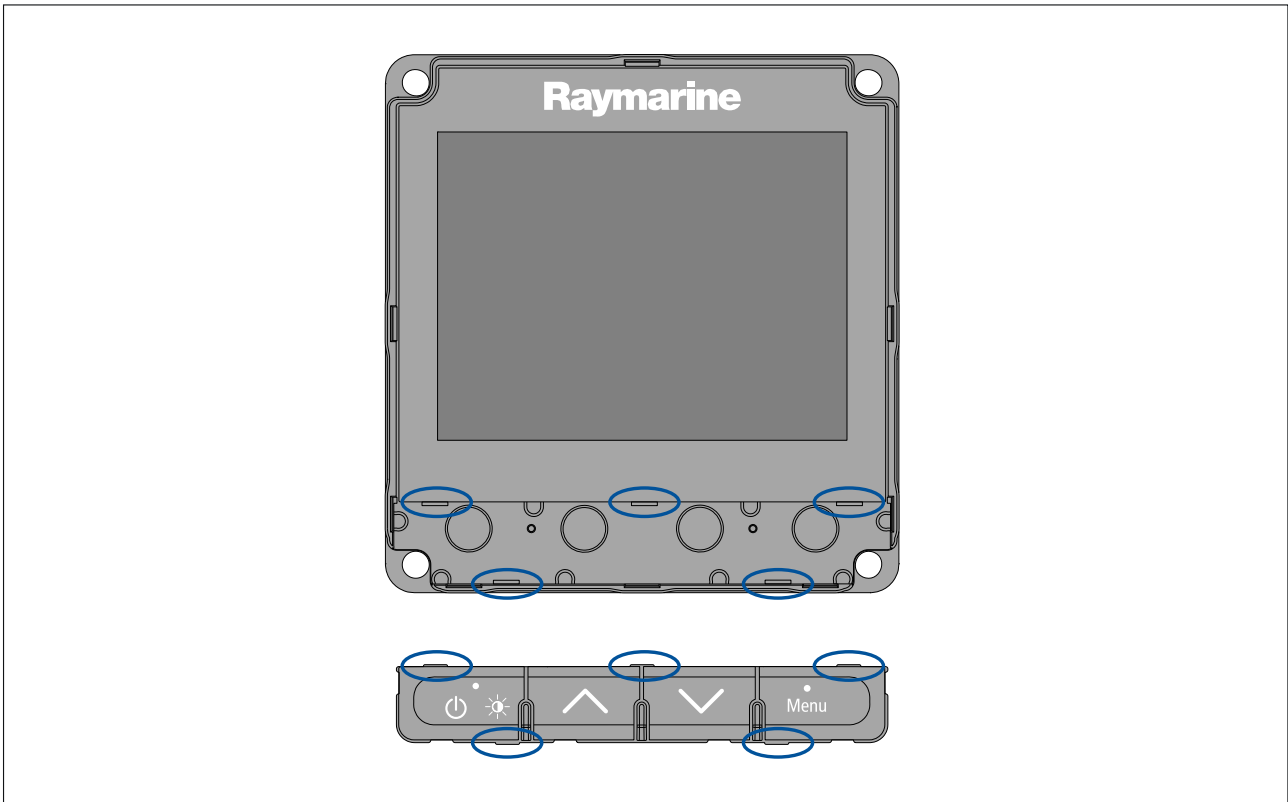

1. Tilt the top edge of the buttonpad forwards and insert the bottom edge into the display, ensuring the tabs line up with their respective slots.

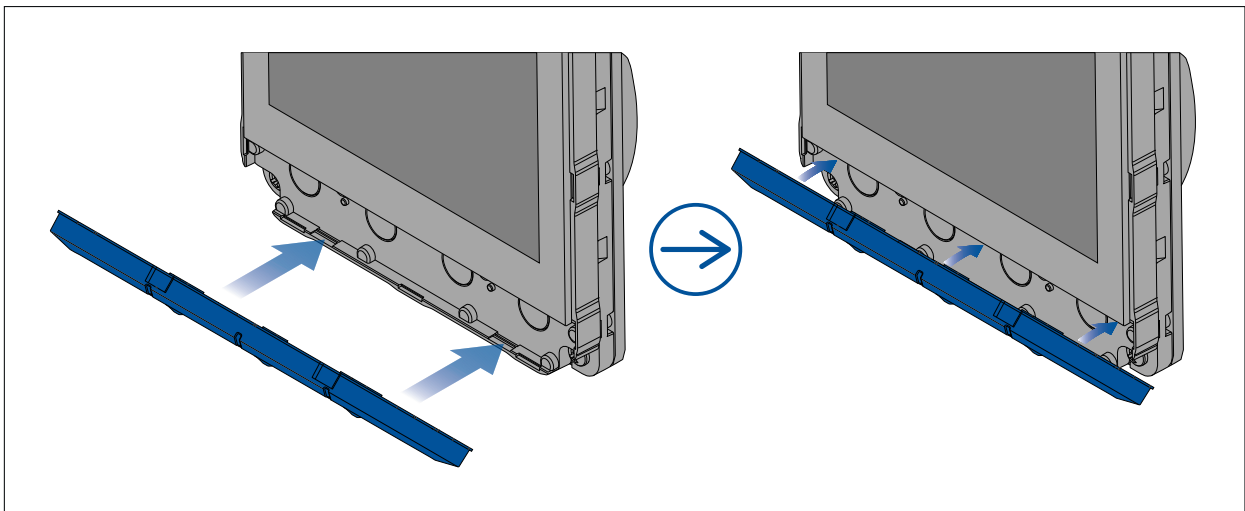

2. Push the top edge of the buttonpad into the display.
3. Using your fingers, apply pressure at each tab location, ensuring that the buttonpad tabs are fully engaged.
4. Refit the bezel.

Chapter 4: Connections

Chapter contents

- [4.1 General cabling guidance on page 30](#)
- [4.2 Connections overview on page 31](#)
- [4.3 Cable ferrite installation on page 32](#)
- [4.4 SeaTalkng[®] power supply on page 32](#)
- [4.5 NMEA 2000 connection on page 37](#)
- [4.6 SeaTalk connection on page 37](#)
- [4.7 Transducer connections on page 38](#)

4.1 General cabling guidance

Cable types and length

It is important to use cables of the appropriate type and length.

- Unless otherwise stated only use cables supplied by Raymarine.
- Where it is necessary to use non-Raymarine cables, ensure that they are of correct quality and gauge for their intended purpose. (e.g.: longer power cable runs may require larger wire gauges to minimize voltage drop along the run).

Cable routing

Cables must be routed correctly, to maximize performance and prolong cable life.

- Do NOT bend cables excessively. Wherever possible, ensure a minimum bend diameter (\emptyset) of 200 mm (7.87 in) / minimum bend radius (R) of 100 mm (3.94 in).

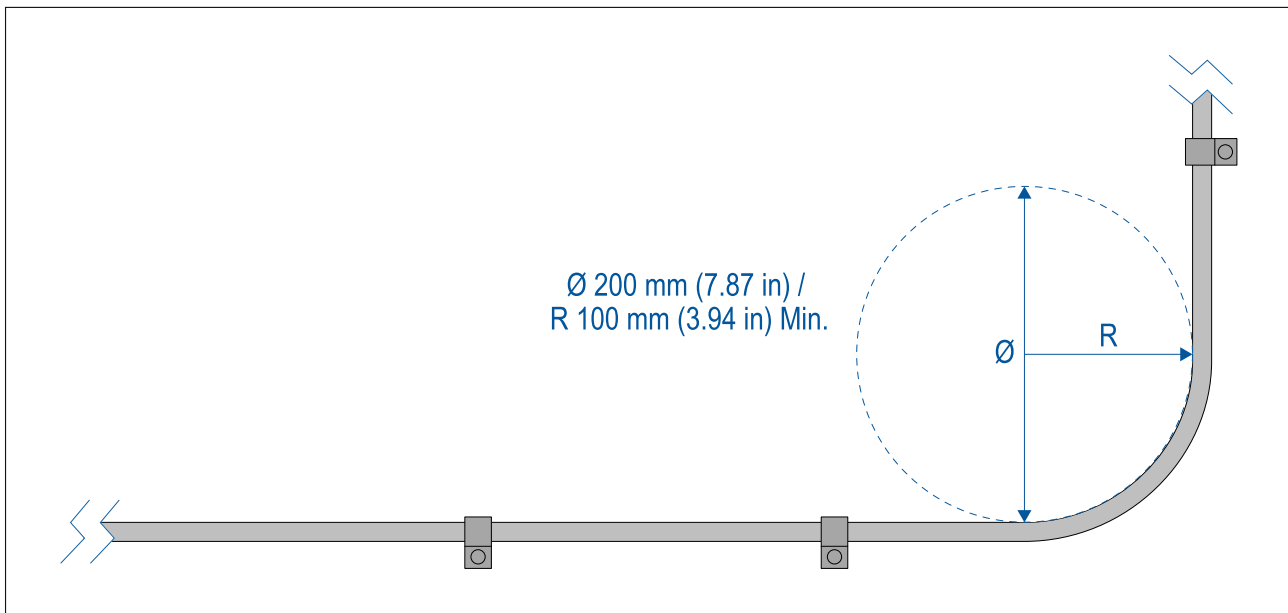

- Protect all cables from physical damage and exposure to heat. Use trunking or conduit where possible. Do NOT run cables through bilges or doorways, or close to moving or hot objects.
- Secure cables in place using cable clips or cable ties. Coil any excess cable and tie it out of the way.
- Where a cable passes through an exposed bulkhead or deckhead, use a suitable watertight feed-through.
- Do NOT run cables near to engines or fluorescent lights.
- Always route data cables as far away as possible from:
 - other equipment and cables,
 - high current carrying AC and DC power lines,
 - antennas.

Strain relief

Use adequate strain relief for cabling to ensure that connectors are protected from strain and will not pull out under extreme sea conditions.

Cable shielding

Ensure that cable shielding is not damaged during installation and that all cables are properly shielded.

4.2 Connections overview

Your product is supplied power and data using the SeaTalkng[®] connector located on the back of the unit.

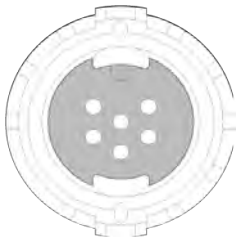
Connector	Connections
	<ul style="list-style-type: none">• SeaTalkng[®] backbone using a SeaTalkng[®] spur cable.• NMEA 2000 backbone using SeaTalkng[®] to DeviceNet adaptor cable (A06045)• SeaTalk[®] backbone using a SeaTalk[®] to SeaTalkng[®] adaptor cable (A06073)

For a list of available cables refer to: [p.57 – Spares and accessories](#)

Connecting SeaTalkng[®] cables

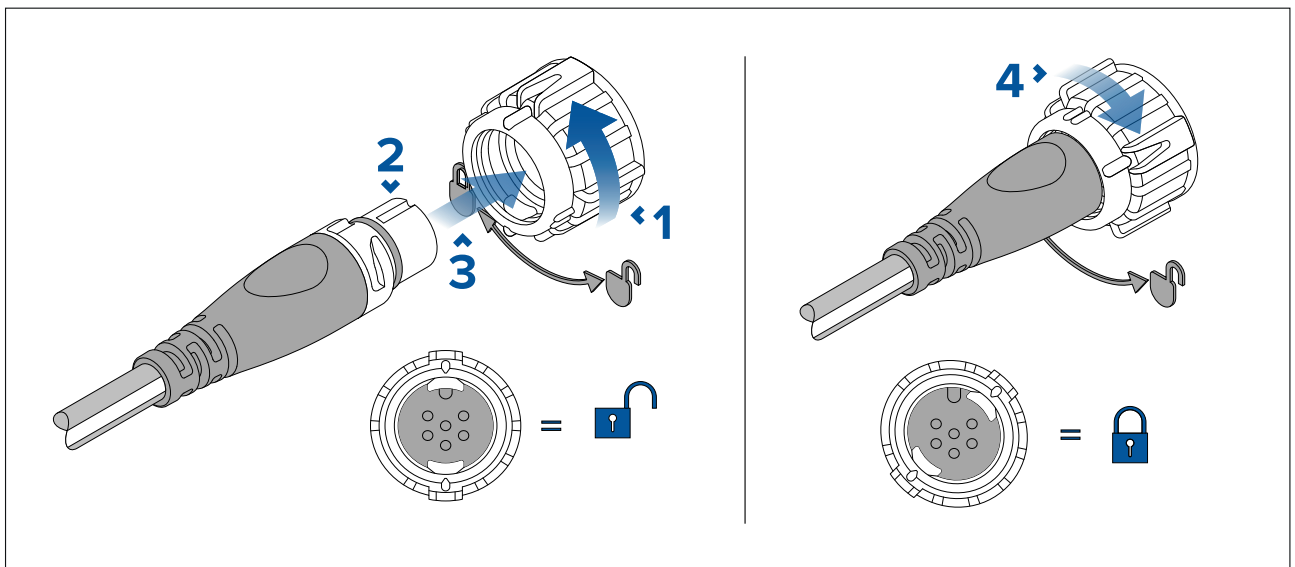

1. Rotate your product's SeaTalkng[®] connector locking collar counter clockwise, so that the connector is in the unlocked position.
2. Ensure the cable's connector is correctly oriented (groove pointing up).
3. Fully insert the cable connector..
4. Rotate the locking collar clockwise (2 clicks) until it is in the locked position.

SeaTalkng[®] product loading

The number of products that can be connected to a SeaTalkng[®] backbone depends on the current draw of each product and the physical length of the backbone cabling.

NMEA 2000 Load Equivalency Numbers (LEN) are used to express the amount of current that is drawn from SeaTalkng[®] products (1 LEN = 50 mA) The LEN for each product can be found in the product's Technical Specification.

LENs are used to determine the power connection point for the SeaTalkng[®] backbone.

4.3 Cable ferrite installation

Your product is supplied with a suppression ferrite clamp. To ensure EMC Compliance, the supplied ferrite must be fitted to the cable according to the following instructions.

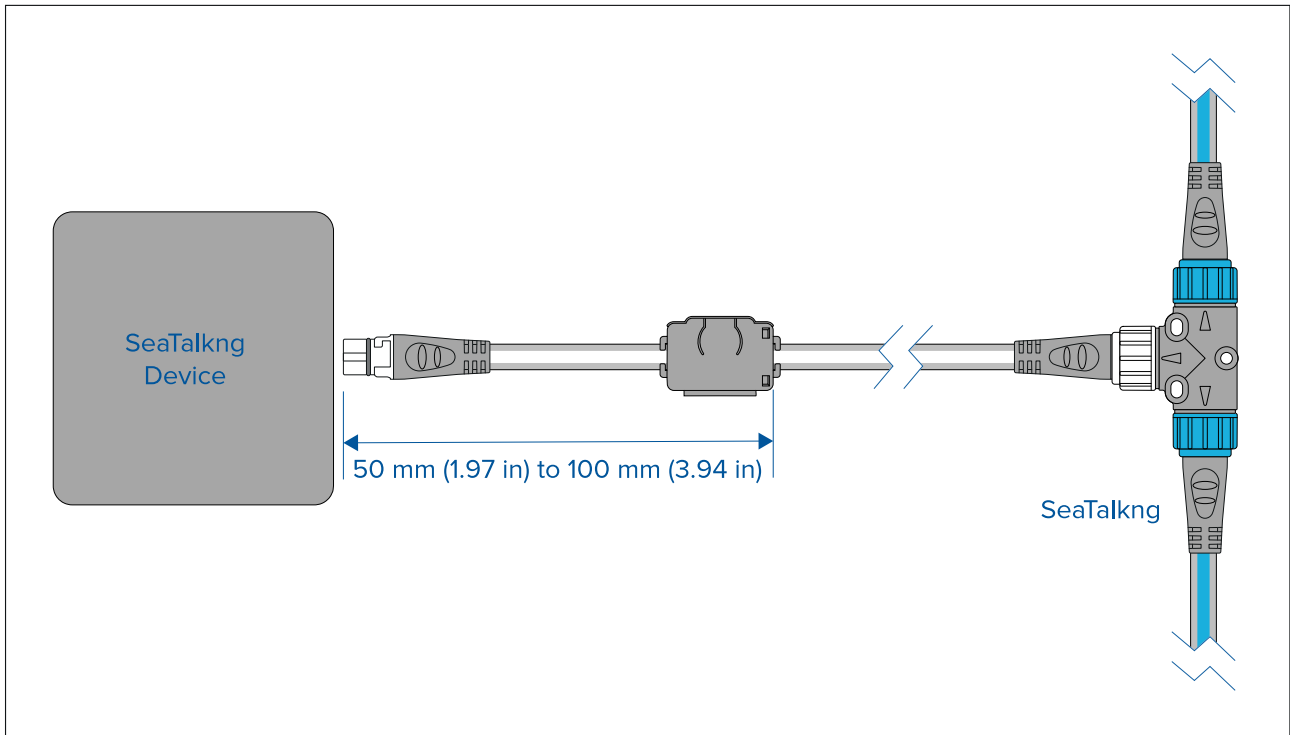

1. The ferrite must be fitted to the end of the SeaTalkng™ spur cable closest to the device.
2. The ferrite must be fitted at the distance specified in the illustration above.
3. Ensure a tight and secure fit so that the ferrite will not move up or down the cable.

4.4 SeaTalkng® power supply

Your product is supplied power via the SeaTalkng® backbone.

A SeaTalkng® backbone requires a single 12 V dc power supply. Power can be supplied to the SeaTalkng® backbone by one of the following methods:

- ⁽¹⁾direct connection to a 12 V dc battery
- connection via a 12 V dc distribution panel
- ⁽²⁾via an Autopilot Control Unit (ACU) (not ACU-100 or 150), or an SPX course computer (not SPX-5) that is connected to the SeaTalkng® backbone.
- for 24 V vessels, via a 5 amp, regulated, continuous 24 V dc to 12 V dc converter

Note:

- ⁽¹⁾The battery used for starting the vessel's engine(s) should NOT be used to power the SeaTalkng® backbone, as this can cause sudden voltage drops when the engines are started.
- ⁽²⁾The ACU-100, ACU-150 or SPX-5 products cannot be used to power the SeaTalkng® backbone.

The SeaTalkng® power cable (A06049) is used to connect the SeaTalkng backbone to your chosen 12 V dc power supply.

SeaTalkng® power connection point

The 12 V dc power supply is connected to a spur connection on the SeaTalkng® backbone.

Large systems

If the backbone length is greater than 60 m (197 ft), the power connection point should be connected at a point that creates a balanced current draw from each side of the backbone. The NMEA 2000 Load Equivalency Number (LEN) is used to determine the power connection point for the backbone.

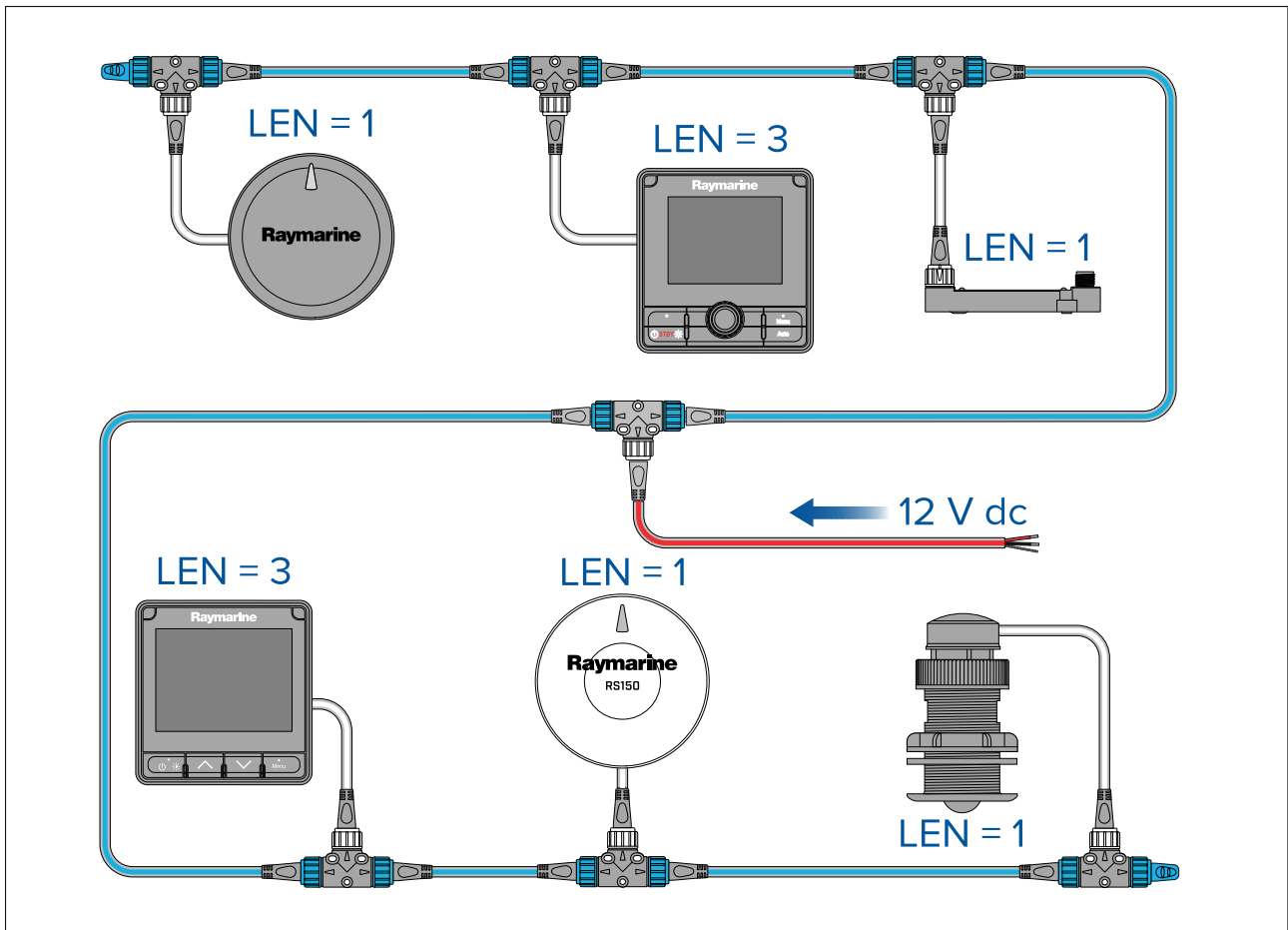

In the example above the backbone has an overall LEN of 10, so the optimum connection point would be to have 5 LEN either side of the connection point.

Small systems

If the backbone length is 60 m (197 ft) or less, the power connection point may be connected at any point in the backbone.

In-line fuse and thermal breaker ratings

The SeaTalkng[®] network's power supply requires an in-line fuse or thermal breaker to be fitted.

- In-line fuse rating: 5 A
- Thermal breaker rating : 3 A (refer to note below)

Note:

The suitable fuse rating for the thermal breaker is dependent on: 1) How many devices you have connected to your SeaTalkng[®] network; and 2) How many devices are sharing the same thermal breaker that your SeaTalkng[®] network is connected to.

SeaTalkng[®] system loading

The maximum loading / LEN for a SeaTalkng[®] system depends on the length of the backbone.

Unbalanced system loading:

- **Backbone Length:** 0 m (0 ft) to 20 m (66 ft) — **Maximum LEN:** 40
- **Backbone Length:** > 20 m (66 ft) to 40 m (131 ft) — **Maximum LEN:** 20
- **Backbone Length:** > 40 m (131 ft) to 60 m (197 ft) — **Maximum LEN:** 14

Balanced system loading:

- **Backbone Length:** 0 m (0 ft) to 60 m (197 ft) — **Maximum LEN:** 100
- **Backbone Length:** > 60 m (197 ft) to 80 m (262 ft) — **Maximum LEN:** 84
- **Backbone Length:** > 80 m (262 ft) to 100 m (328 ft) — **Maximum LEN:** 60
- **Backbone Length:** > 100 m (328 ft) to 120 m (394 ft) — **Maximum LEN:** 50

- **Backbone Length:** > 120 m (394 ft) to 160 m (525 ft) — **Maximum LEN:** 40
- **Backbone Length:** > 160 m (525 ft) to 200 m (656 ft) — **Maximum LEN:** 32

Power distribution — SeaTalkng®

Recommendations and best practice.

- Only use approved SeaTalkng® power cables. Do NOT use a power cable designed for, or supplied with, a different product.
- See below for more information on implementation for some common power distribution scenarios.

Important:

- When planning and wiring, take into consideration other products in your system, some of which (e.g. sonar modules) may place large power demand peaks on the vessel's electrical system, which may impact the voltage available to other products during the peaks.
- The information provided below is for guidance only, to help protect your product. It covers common vessel power arrangements, but does NOT cover every scenario. If you are unsure how to provide the correct level of protection, please consult an authorized Raymarine dealer or a suitably qualified professional marine electrician.

SeaTalkng® power cable (A06049)

When powering the SeaTalkng® bus (backbone or 5-way connector) from a battery or distribution panel, the A06049 power cable must be used.

All 3 cores of the cable must be connected correctly:

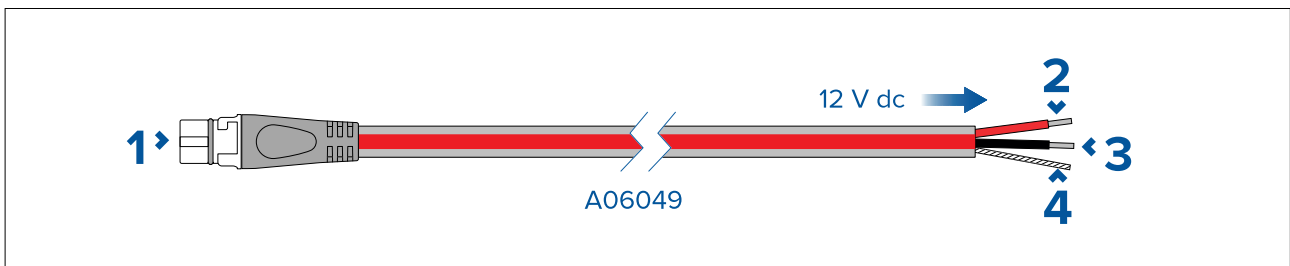

1. SeaTalkng® spur connector — connects to spur connection on the SeaTalkng® network.
2. + Red (positive) wire — connects to battery or distribution panel positive terminal.
3. – Black (negative) wire — connects to battery or distribution panel negative terminal.
4. Ground wire connects to RF ground point, if no ground point is available connect to the battery negative (-) terminal.

Implementation — connection to distribution panel

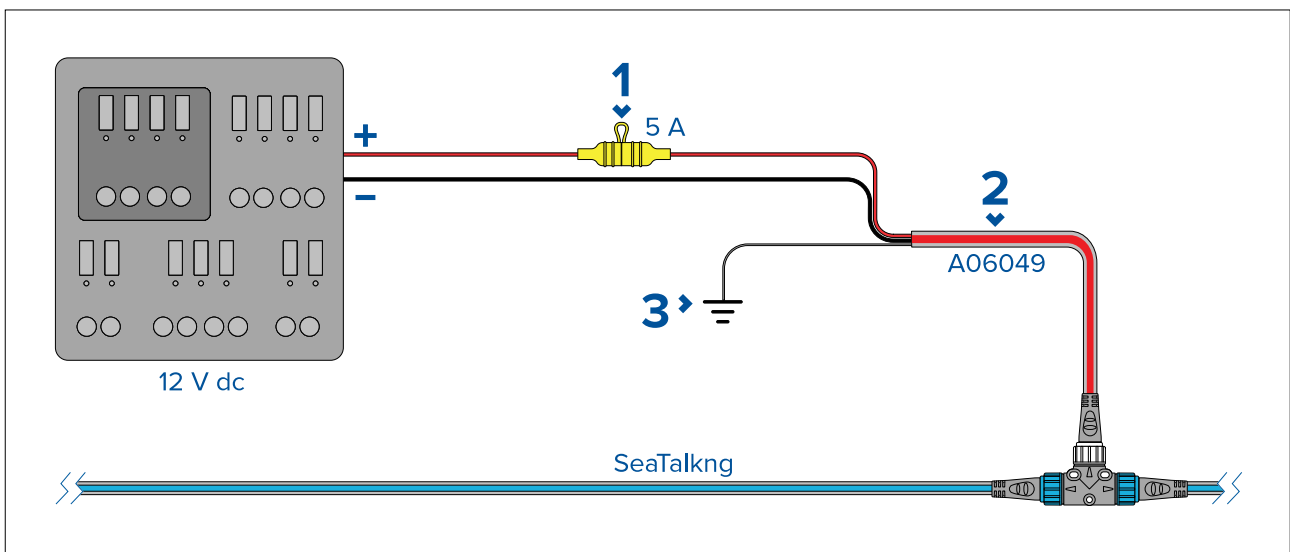

1. Waterproof fuse holder with 5 A inline fuse must be fitted (not supplied).
2. SeaTalkng® power cable.

3. RF Ground connection point for drain wire.

- Ideally, the SeaTalkng[®] power cable should be connected to a suitable breaker or switch on the vessel's distribution panel or factory-fitted power distribution point. It is recommended that a 5 A inline fuse is fitted to the red (positive) wire of the SeaTalkng[®] power cable.
- The distribution point should be fed from the vessel's primary power source by 8 AWG (8.36 mm²) cable.
- Ideally, all equipment should be wired to individual suitably-rated thermal breakers or fuses, with appropriate circuit protection. Where this is not possible and more than 1 item of equipment shares a breaker, use individual in-line fuses for each power circuit to provide the necessary protection.

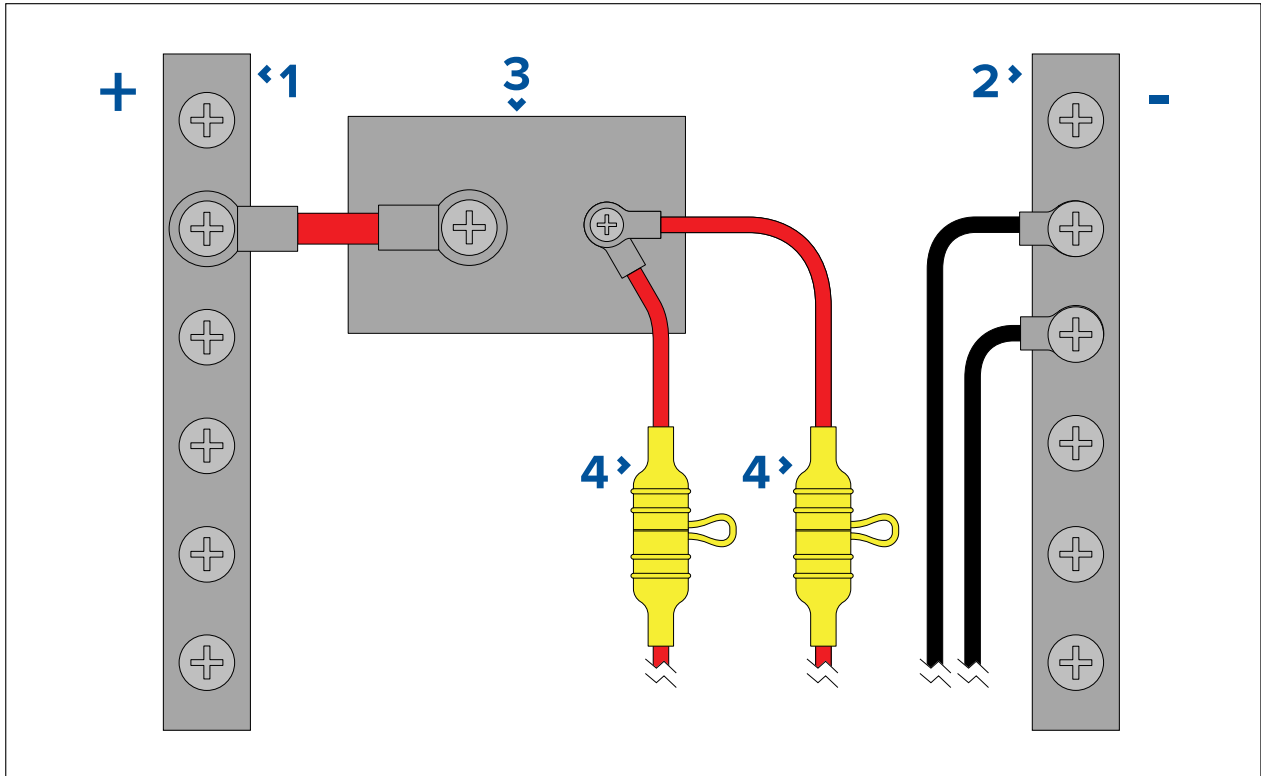

1. Positive (+) bar
2. Negative (-) bar
3. Circuit breaker
4. Waterproof fuse holder with 5 A inline fuse must be fitted (not supplied).

Important:

Observe the recommended fuse / breaker ratings provided in the product's documentation, however be aware that the suitable fuse / breaker rating is dependent on the number of devices being connected.

Implementation — direct connection to battery

- SeaTalkng[®] Where connection to a power distribution panel is not possible, the power cable may be connected to the vessel's battery..
- You **MUST** fit a suitably rated fuse or breaker between the red wire and the battery's positive terminal.
- Refer to the inline fuse ratings provided in the product's documentation.
- If you need to extend the length of the power cable, ensure you use suitably rated cable and that sufficient power (12 V dc) is available at the SeaTalkng[®] backbone's power connection.

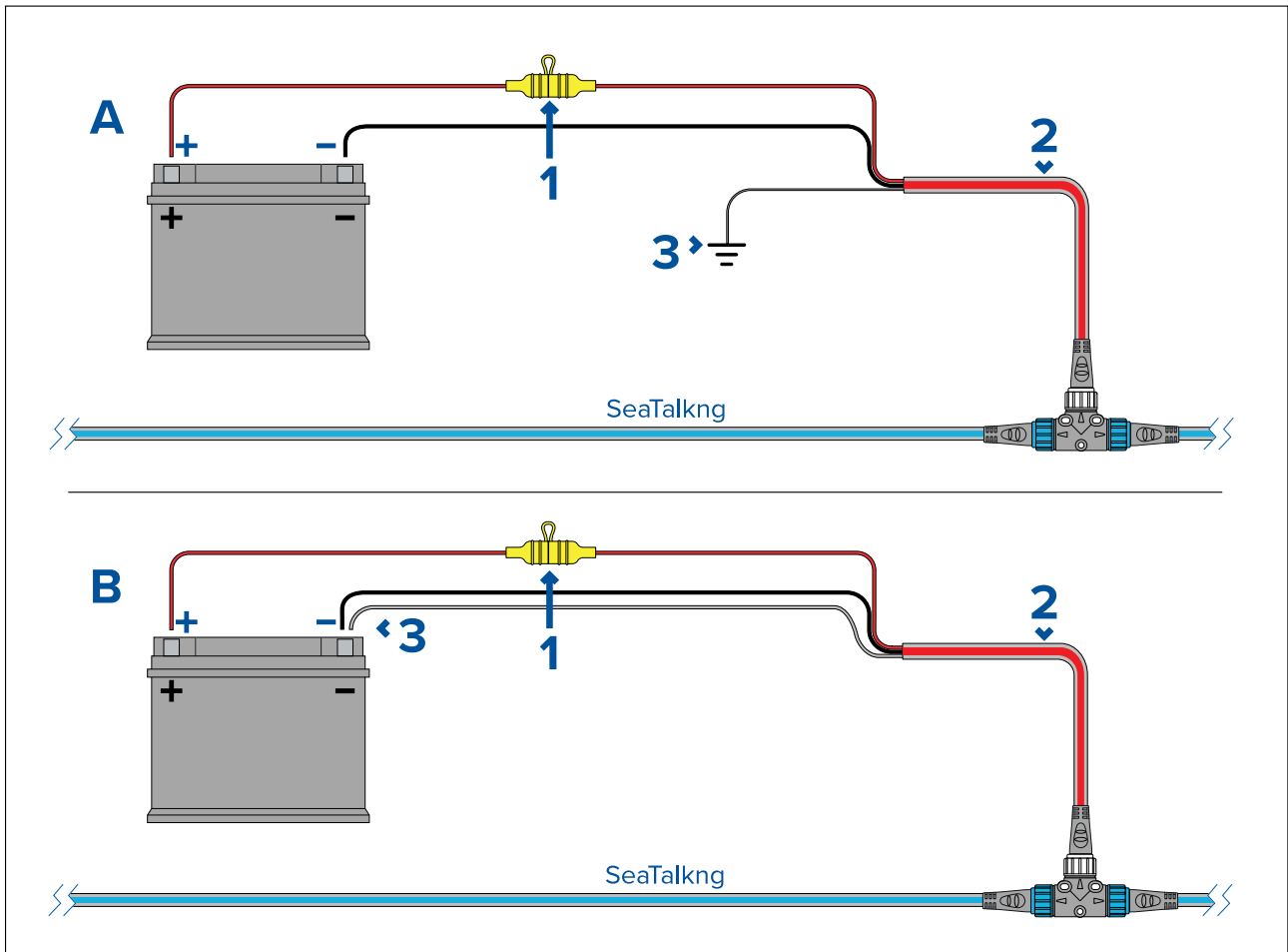

1. Waterproof fuse holder with 5 A inline fuse must be fitted (not supplied).
2. SeaTalkng® power cable.
3. Drain wire connection point.

Battery connection scenario A:

Suitable for a vessel with a common RF ground point. In this scenario, the power cable's drain wire should be connected to the vessel's common RF ground point.

Battery connection scenario B:

Suitable for a vessel without a common RF ground point. In this scenario the power cable's drain wire should be connected directly to the battery's negative terminal.

SeaTalkng® Power cable extension

If you need to extend the length of the SeaTalkng® power cable, ensure you use suitably rated cable and that sufficient power is available at the SeaTalkng® backbone's power connection point:

- For power cable extensions, a **minimum** wire gauge of 16 AWG (1.31 mm²) is recommended. For cable runs longer than 15 meters, you may need to consider a thicker wire gauge (e.g. 14 AWG (2.08 mm²), or 12 AWG (3.31 mm²)).
- An important requirement for all lengths of power cable (including any extension) is to ensure that there is a continuous **minimum** voltage at the product's power connector of 10.8 V dc, with a fully flat battery at 11 V dc.

Important:

Be aware that some products in your system (such as sonar modules) can create voltage peaks at certain times, which may impact the voltage available to other products during the peaks.

More information

It is recommended that best practice is observed in all vessel electrical installations, as detailed in the following standards:

- BMEA Code of Practice for Electrical and Electronic Installations in Boats
- NMEA 0400 Installation Standard

- ABYC E-11 AC & DC Electrical Systems on Boats
- ABYC A-31 Battery chargers and Inverters
- ABYC TE-4 Lightning Protection



Warning: Product grounding

Before applying power to this product, ensure it has been correctly grounded, in accordance with the instructions provided.



Warning: Positive ground systems

Do not connect this unit to a system which has positive grounding.

4.5 NMEA 2000 connection

The product can be connected to a NMEA 2000 backbone using a SeaTalkng[®] to DeviceNet adaptor cable.

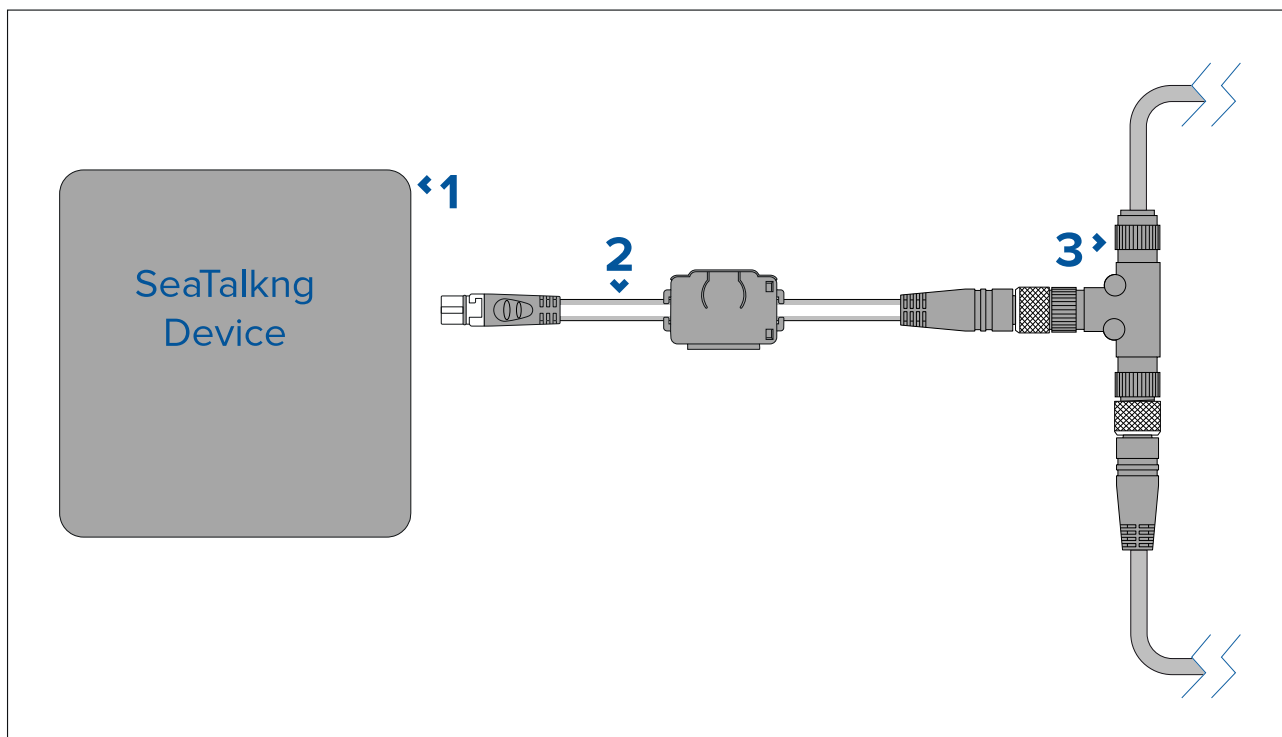

1. SeaTalkng[®] device
2. SeaTalkng[®] to DeviceNet adaptor cable (e.g.: A06075)
3. DeviceNet T piece connector

4.6 SeaTalk connection

The display can be connected to a SeaTalk[®] network using a SeaTalk[®] to SeaTalkng[®] adaptor cable.

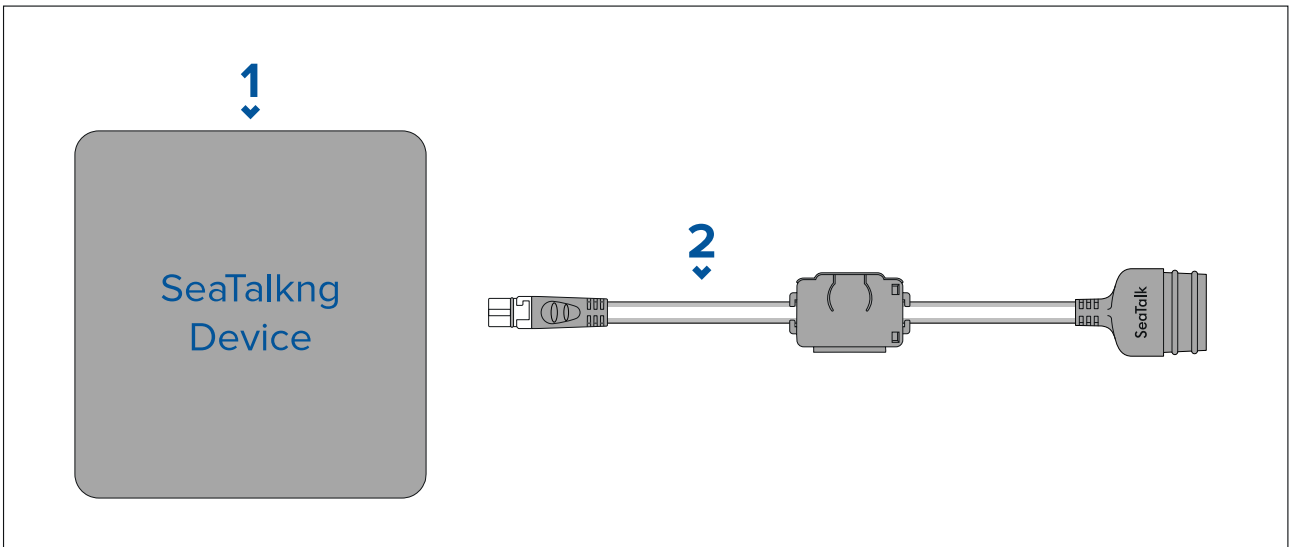

1. SeaTalkng[®] device (e.g.: i70s)
2. SeaTalk[®] to SeaTalkng[®] adaptor cable i.e.: A06073 or A06047

4.7 Transducer connections

Transducers must be connected to the same SeaTalkng[®] backbone as the display.
 Transducers can be connected using either an iTC-5 or legacy transducer pods.

iTC-5 connection

Analog transducer data can be transmitted to the display using an iTC-5.

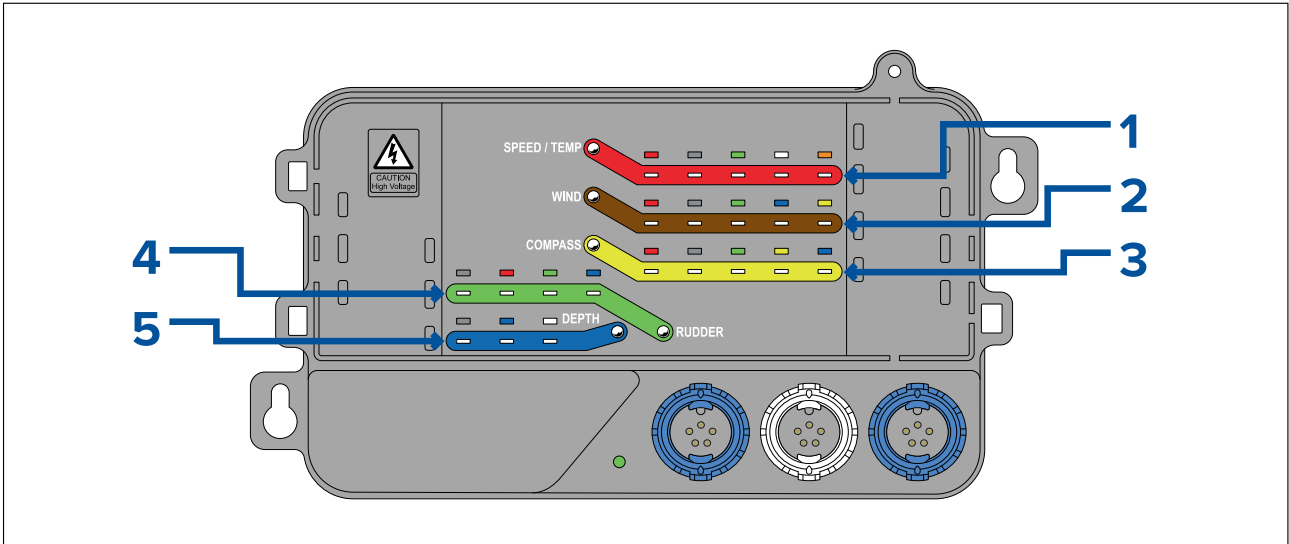

1. Speed & Temperature transducer connections
2. Wind transducer connections
3. Compass connections
4. Rudder reference transducer connections
5. Depth transducer connections

For details on connecting an iTC-5 to the SeaTalkng[®] backbone and connecting transducers to the iTC-5 refer to the documentation provided with the iTC-5.

Transducer pod connection

Analog transducer data can be transmitted to the display using legacy transducer pods.

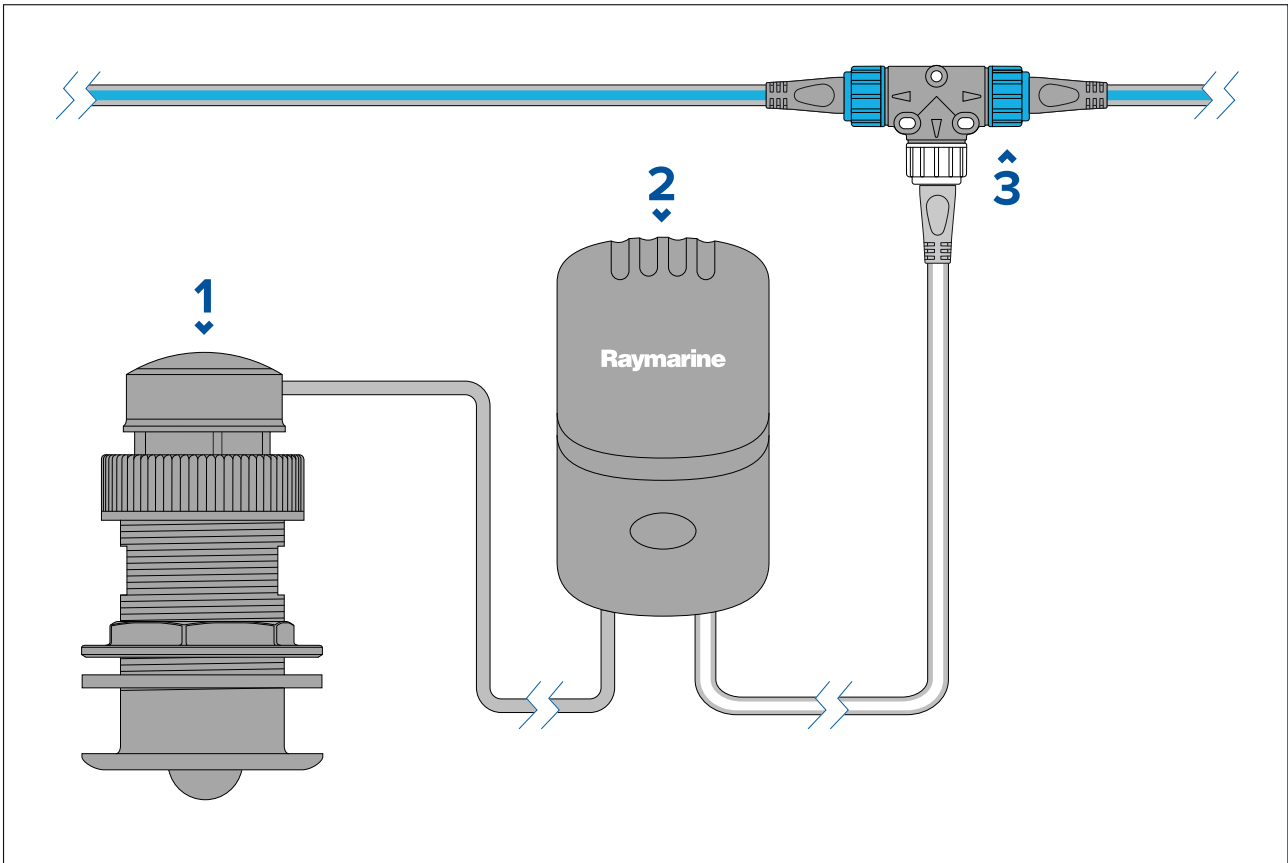

1. Analog transducer (e.g.: speed and temperature transducer)
2. Transducer pod (e.g.: Speed pod)
3. SeaTalkng[®] T-Piece connector (A06028)

Connect the transducer to the pod, the pod terminals are color-coded, ensure that each wire is connected to the corresponding terminal.

Connect the pod to the SeaTalkng[®] backbone using a SeaTalkng[®] to bare wire spur cable (e.g.: A06043) and a T-piece connector. Pods must be located no farther than 400 mm (15.75 in.) from the connection point on the backbone.

Connecting legacy transducer pods to SeaTalkng

Legacy transducer pods use color coded, spring retention connectors for the SeaTalkng[®] connection. A bare ended SeaTalkng[®] spur cable (e.g.: A06043) is required.

1. Prepare the bare ended wires of the SeaTalkng[®] spur cable as shown below:

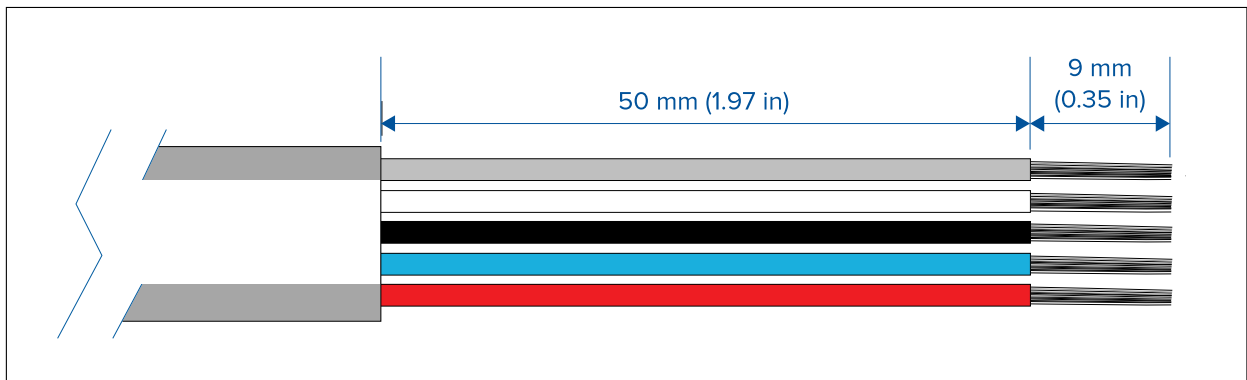

2. Fit each wire into the corresponding color coded connector. To fit the wires use a flat blade screw driver to push in the spring retention clip and hold it in the open position, then slide the wire fully into the connector and release the spring retention clip.

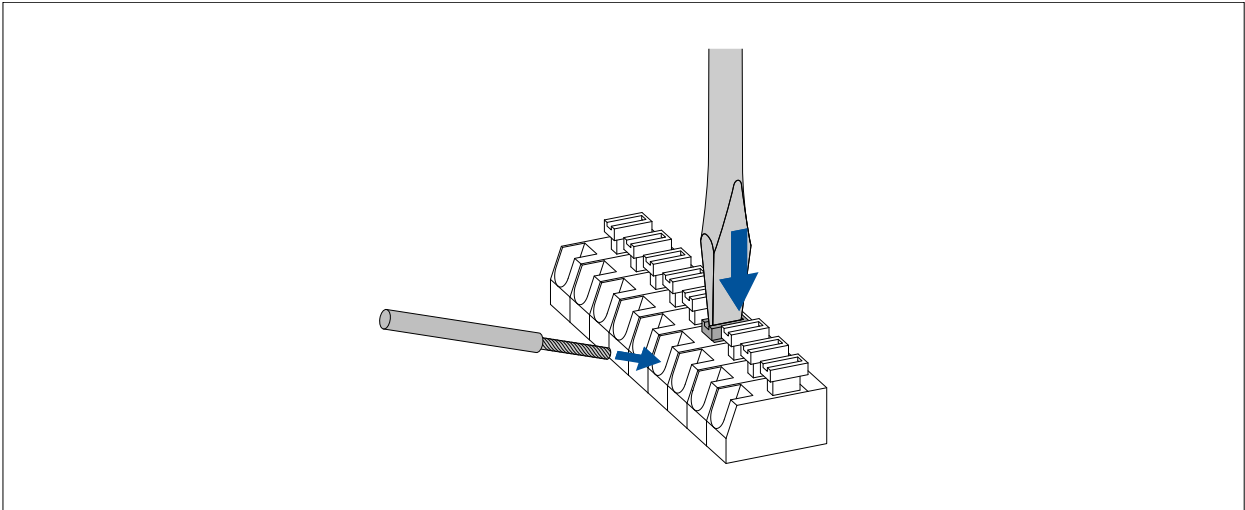

Fitting spade connectors to transducer wires

Legacy transducer pods use color coded male spade connectors for the transducer connection. 1/8th size female spade connectors are required to be fitted to the transducer wires.

If spade terminals need to be fitted follow the steps below:

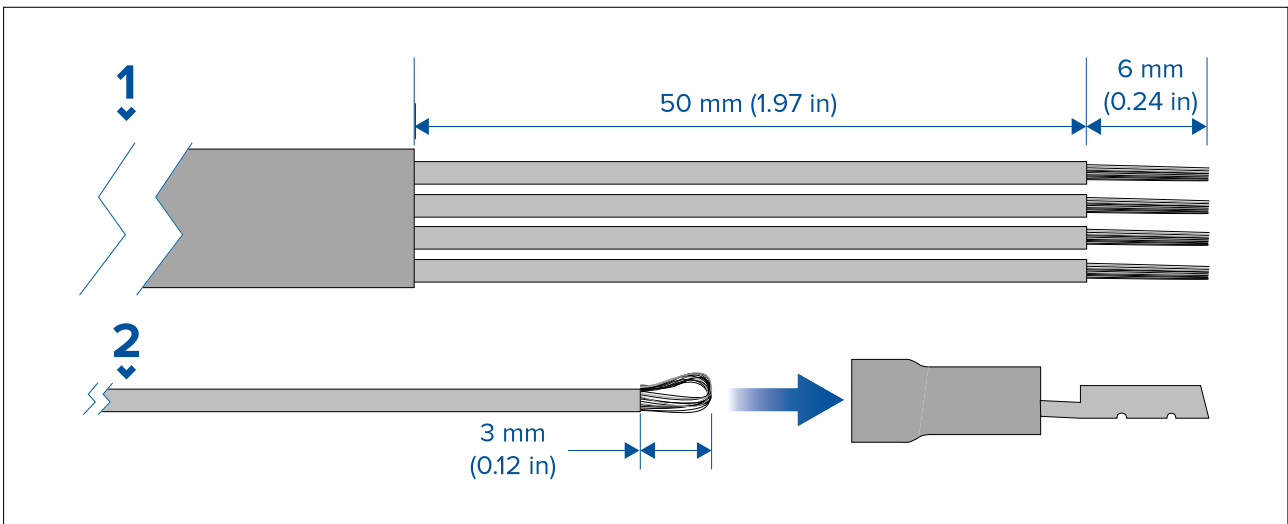

1. Prepare the cable as shown in 1 above.
2. Fold back the wire strands and insert into the spade connector as shown in 2 above.
3. Ensure the wire strands do not extend beyond the rear of the spade connector insulation.
4. Crimp the connector to the wire.

Connecting transducers to legacy transducer pods

Follow the steps below to connect the transducer wires to the transducer pod.

Example — Wind pod connection

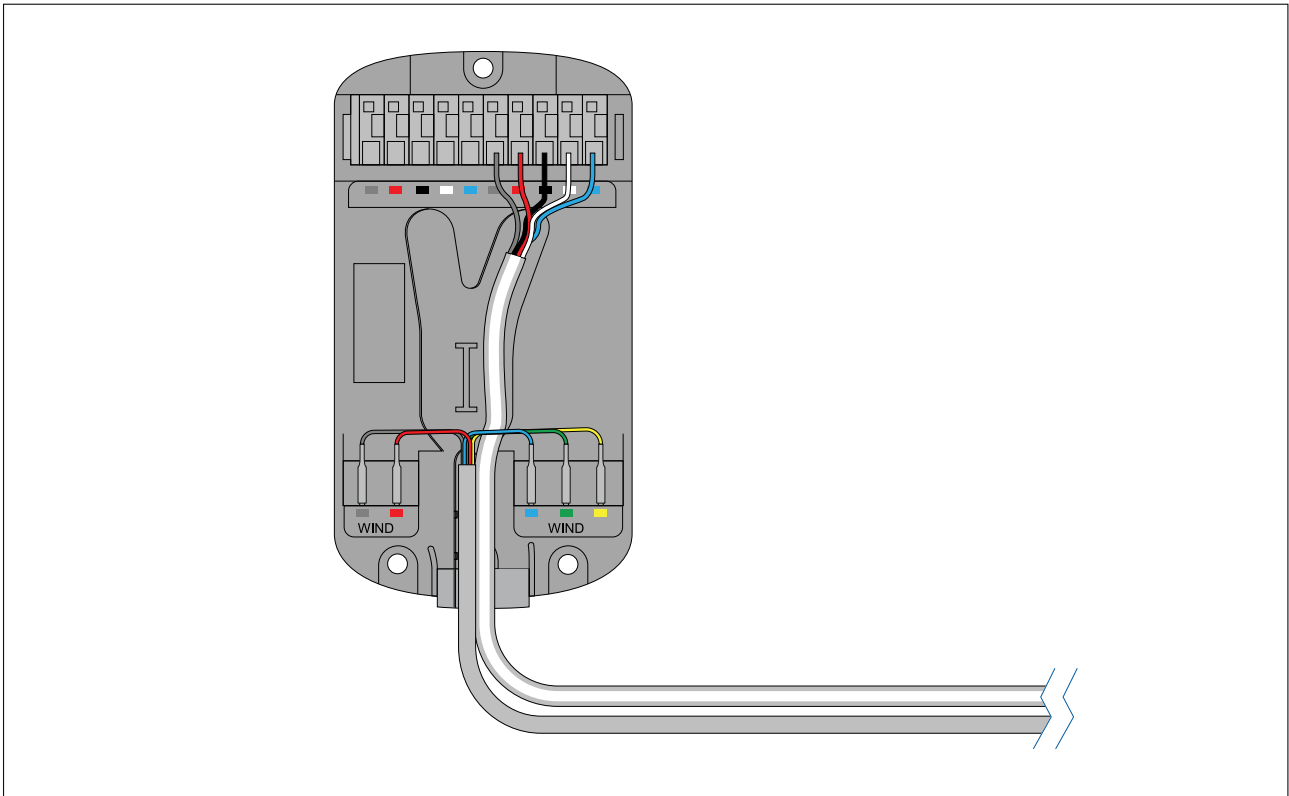

1. Fit each transducer wire to the relevant color coded connector on the transducer pod.
2. Ensure each spade terminal is pushed fully on to the pod connector.

Chapter 5: Maintenance

Chapter contents

- 5.1 Service and maintenance on page 44
- 5.2 Routine equipment checks on page 44
- 5.3 Product cleaning on page 44
- 5.4 Cleaning the display case on page 44
- 5.5 Cleaning the display screen on page 44
- 5.6 Cleaning the sun cover on page 45

5.1 Service and maintenance

This product contains no user serviceable components. Please refer all maintenance and repair to authorized Raymarine dealers. Unauthorized repair may affect your warranty.

5.2 Routine equipment checks

It is recommended that you perform the following routine checks, on a regular basis, to ensure the correct and reliable operation of your equipment:

- Examine all cables for signs of damage or wear and tear.
- Check that all cables are securely connected.

5.3 Product cleaning

Best cleaning practices.

When cleaning products:

- Switch off power supply.
- Use a clean damp cloth to wipe clean.
- Do NOT use: abrasive, acidic, ammonia, solvent or other chemical based cleaning products.
- Do NOT use a jet wash.

5.4 Cleaning the display case

The display is a sealed unit and does not require regular cleaning. If it is necessary to clean the display, follow this basic procedure:

1. Switch off the power to the display.
2. Wipe the case with a clean, lint-free cloth.
3. If necessary, use a mild detergent to remove grease marks.

5.5 Cleaning the display screen

A coating is applied to the display screen. This makes it water repellent, and prevents glare. To avoid damaging this coating, follow this procedure:

1. Switch off the power to the display.
2. Rinse the screen with fresh water to remove all dirt particles and salt deposits.
3. Allow the screen to dry naturally.
4. If any smears remain, very gently wipe the screen with a clean microfibre cleaning cloth.

Transducer cleaning

You must clean your transducer regularly to remove organic growth. Organic growth can build up quickly on the bottom face of your transducer; this can impact transducer performance in a matter of weeks.

Important:

- When cleaning growth from an anti-fouled transducer, take care not to let paint dust and other debris enter the water, as this can have an impact on aquatic life.
- Take care not to scratch the surface of the transducer as this can impact transducer performance.
- Do NOT use harsh cleaning solvents such as acetone as this will damage the transducer.

Follow the guidance below to clean growth from your transducer:

- use a soft cloth and a mild household cleaning detergent to clean mild growth build up.

- use a scouring pad, such as a green Scotch Brite™ pad and a mild household cleaning detergent to clean moderate growth build up.
- you may need to use a fine grade wet and dry paper and a mild household cleaning detergent to clean severe build up.

5.6 Cleaning the sun cover

The supplied sun cover features an adhesive surface. In certain conditions unwanted contaminants may stick to this surface. To avoid damaging the monitor display, clean the sun cover regularly following this procedure:

1. Carefully remove the sun cover from the display.
2. Rinse the sun cover with fresh water to remove all dirt particles and salt deposits.
3. Allow the sun cover to dry naturally.

Chapter 6: Troubleshooting

Chapter contents

- [6.1 Troubleshooting on page 48](#)
- [6.2 Power up troubleshooting on page 48](#)
- [6.3 System data troubleshooting on page 49](#)
- [6.4 Miscellaneous troubleshooting on page 49](#)

6.1 Troubleshooting

The troubleshooting information provides possible causes and corrective action required for common problems associated with installation and operation of your product.

Before packing and shipping, all Raymarine products are subjected to comprehensive testing and quality assurance programs. If you do experience problems with your product this section will help you to diagnose and correct problems in order to restore normal operation.

If after referring to this section you are still having problems with your product, please refer to the Technical support section of this manual for useful links and Raymarine Product Support contact details.

6.2 Power up troubleshooting

Product does not turn on or keeps turning off

- **Blown fuse / tripped breaker.**
 1. Check condition of the SeaTalkng backbone power connection 5 A fuse and if applicable distribution panel breaker, replace if necessary.
 2. If the fuse keeps blowing check for cable damage, broken connector pins or incorrect wiring.
- **Poor / damaged / insecure SeaTalkng cabling and connections**
 1. Check the vessel's battery voltage and the condition of the battery terminals and power supply cables, ensuring connections are secure, clean and free from corrosion. Replace if necessary.
 2. Check the SeaTalkng power cable and power supply connection for signs of damage or corrosion, and replace if necessary.
 3. Check the SeaTalkng backbone cabling and connectors for signs of damage or corrosion, and replace if necessary.
 4. Check the SeaTalkng power, backbone and product spur cable connectors are correctly orientated, fully inserted into the spur connectors and in the locked position.
 5. With the display turned on, try flexing the display's spur cable near to the display's connector to see if this causes the display to restart or lose power. Replace if necessary.
 6. With the product under load, using a multi-meter, check for high voltage drop across all connectors / fuses etc, and replace if necessary.
- **Incorrect power connection**
 1. The power supply may be wired incorrectly, ensure the SeaTalkng power connection instructions have been followed and that the backbone has one single source of 12 V dc power..

Product will not start up (restart loop)

- **Power supply and connection**
 1. Refer to 'Product does not turn on or keeps turning off' information above.
- **Software corruption**
 1. In the unlikely event that the product's software has become corrupted, try downloading and installing the latest software from the Raymarine website. refer to your Multifunction Display's operation instructions for details on updating software for SeaTalkng devices.
 2. In the case of a restart loop attempt a factory reset using the following instructions:
[p.48 – Performing a Factory Reset](#)

Performing a Factory Reset

To reset your unit to factory default settings follow the steps below.

Note: Performing a factory reset will erase all saved data and customized settings.

1. Press the **Menu** button.
2. Select **Set Up**.
3. Select **Factory Reset**.

4. Select **Yes**.

Your unit will now reset itself to factory default settings.

6.3 System data troubleshooting

Aspects of the installation can cause problems with the data shared between connected equipment. Such problems, their possible causes and solutions are described here.

Transducer, instrument, engine or other system data is unavailable at all displays.

- **Data is not being received at the display.**
 1. Check the relevant product and or network cabling and connections (e.g. SeaTalkng backbone) for signs of damage or corrosion, and replace if necessary.
- **Data source (e.g. instrument display or engine interface) is not operating.**
 1. Check the source of the missing data (e.g. transducer or engine interface) for signs of damage or corrosion, and replace if necessary.
 2. If possible, check that the data source is correctly powered and operational.
 3. Refer to the instructions provided with the equipment to ensure it has been correctly installed.
- **Software mismatch between equipment may prevent communication.**
 1. Ensure all products have the latest software installed.

Transducer, instrument or other system data is missing from some but not all displays.

- **Connection problem.**
 1. Check the product's SeaTalkng spur cable and connections for signs of damage or corrosion, and replace if necessary.
- **Software corruption.**
 1. In the unlikely event that the product's software has become corrupted, try downloading and installing the latest software from the Raymarine website. refer to your Multifunction Display's operation instructions for details on updating software for SeaTalkng devices.
 2. In the case of a restart loop attempt a factory reset using the following instructions:
[p.48 — Performing a Factory Reset](#)
- **Software mismatch between equipment may prevent communication.**
 1. Ensure all products have the latest software installed.

Incorrect data reported.

- Transducer calibration error
 1. Switch off power supply to system and switch back on again.
 2. Re-calibrate or re-configure data source following instructions provided with the relevant devices.

6.4 Miscellaneous troubleshooting

Miscellaneous problems and their possible causes and solutions are described here.

Display behaves erratically.

Frequent unexpected resets or system crashes and other erratic behavior:

- **Intermittent problem with power to the display.**
 1. Check relevant fuses and breakers.
 2. Check that the power supply cable is sound and that all connections are tight and free from corrosion.
 3. Check that the power source is of the correct voltage and sufficient current.
- **Software mismatch between equipment may prevent communication.**
 1. Ensure all products have the latest software installed.
- **Corrupt data / other unknown issue.**

1. In the unlikely event that the product's software has become corrupted, try downloading and installing the latest software from the Raymarine website. refer to your Multifunction Display's operation instructions for details on updating software for SeaTalkng devices.
2. Check the data source for correct operation.

Chapter 7: Technical support

Chapter contents

- [7.1 Raymarine product support and servicing on page 52](#)
- [7.2 Viewing product information on page 53](#)

7.1 Raymarine product support and servicing

Raymarine provides a comprehensive product support service, as well as warranty, service, and repairs. You can access these services through the Raymarine website, telephone, and e-mail.

Product information

If you need to request service or support, please have the following information to hand:

- Product name.
- Product identity.
- Serial number.
- Software application version.
- System diagrams.

You can obtain this product information using diagnostic pages of the connected MFD.

Servicing and warranty

Raymarine offers dedicated service departments for warranty, service, and repairs.

Don't forget to visit the Raymarine website to register your product for extended warranty benefits:

<http://www.raymarine.co.uk/display/?id=788>.

United Kingdom (UK), EMEA, and Asia Pacific:

- E-Mail: emea.service@raymarine.com
- Tel: +44 (0)1329 246 932

United States (US):

- E-Mail: rm-usrepair@flir.com
- Tel: +1 (603) 324 7900

Web support

Please visit the "Support" area of the Raymarine website for:

- **Manuals and Documents** — <http://www.raymarine.com/manuals>
- **Technical support forum** — <http://forum.raymarine.com>
- **Software updates** — <http://www.raymarine.com/software>

Worldwide support

United Kingdom (UK), EMEA, and Asia Pacific:

- Help desk: <https://raymarine.custhelp.com/app/ask>
- Tel: +44 (0)1329 246 777

United States (US):

- Help desk: <https://raymarine.custhelp.com/app/ask>
- Tel: +1 (603) 324 7900 (Toll-free: +800 539 5539)

Australia and New Zealand (Raymarine subsidiary):

- E-Mail: aus.support@raymarine.com
- Tel: +61 2 8977 0300

France (Raymarine subsidiary):

- E-Mail: support.fr@raymarine.com
- Tel: +33 (0)1 46 49 72 30

Germany (Raymarine subsidiary):

- E-Mail: support.de@raymarine.com
- Tel: +49 40 237 808 0

Italy (Raymarine subsidiary):

- E-Mail: support.it@raymarine.com
- Tel: +39 02 9945 1001

Spain (Authorized Raymarine distributor):

- E-Mail: sat@azimut.es

- Tel: +34 96 2965 102

Netherlands (Raymarine subsidiary):

- E-Mail: support.nl@raymarine.com
- Tel: +31 (0)26 3614 905

Sweden (Raymarine subsidiary):

- E-Mail: support.se@raymarine.com
- Tel: +46 (0)317 633 670

Finland (Raymarine subsidiary):

- E-Mail: support.fi@raymarine.com
- Tel: +358 (0)207 619 937

Norway (Raymarine subsidiary):

- E-Mail: support.no@raymarine.com
- Tel: +47 692 64 600

Denmark (Raymarine subsidiary):

- E-Mail: support.dk@raymarine.com
- Tel: +45 437 164 64

Russia (Authorized Raymarine distributor):

- E-Mail: info@mikstmarine.ru
- Tel: +7 495 788 0508

7.2 Viewing product information

1. Press the **Menu** button.
2. Select **Set-up**.
3. Select **Diagnostics**.
4. Select **About Display**.

A range of information is displayed, including the software version and Serial number.

5. Use the **Up** and **Down** buttons to cycle through the information.

Chapter 8: Technical specification

Chapter contents

- [8.1 Technical specification on page 56](#)

8.1 Technical specification

Nominal supply voltage	12 V dc
Operating voltage range	9 V dc to 16 V dc (protected up to 32 V dc)
Current	143 mA
Power consumption	1.7 W
LEN (Refer to the SeaTalk ^{ng} reference manual for further information.)	3
Operating Temperature Range	-25°C to +55°C (-13°F to +131°F)
Storage Temperature Range	-30°C to 70°C (-22°F to 158°F)
Relative Humidity	93% Max.
Water proofing	IPX6 and IPX7
Display screen	<ul style="list-style-type: none"> • 4.1" TFT LCD display • 16 bit color (64k colors) • Resolution: 320(H) x 240(V) • Brightness: 1,200 cd/m2
Data connections	1 x SeaTalk^{ng} connector
Conformance	<ul style="list-style-type: none"> • NMEA 2000 certification pending • Europe 2004/108/EC • Australia and New Zealand C-Tick, compliance level 2

Chapter 9: Spares and accessories

Chapter contents

- 9.1 Spares and Accessories on page 58
- 9.2 Smart transducers on page 58
- 9.3 Instrument Depth, Speed and Temperature (DST) transducers on page 59
- 9.4 Instrument Depth transducers on page 59
- 9.5 Instrument Speed and Temperature transducers on page 60
- 9.6 Instrument Wind Vane transducer on page 61
- 9.7 Instrument Rotavecta transducer on page 62
- 9.8 Other transducers on page 62
- 9.9 SeaTalkng[®] cables and accessories on page 63

9.1 Spares and Accessories

- **A80353** — Black bezel for i70s / p70s / p70Rs
- **A80354** — Gunmetal bezel I for i70s / p70s / p70Rs
- **A80357** — Suncover for i70s / p70s

9.2 Smart transducers

Smart transducers can be connected directly to the **SeaTalk^{ng}** backbone without the need for an **iTC-5** or transducer pod.

The smart transducers listed below are compatible with the following displays:

- i70 / i70s
- Multifunction displays

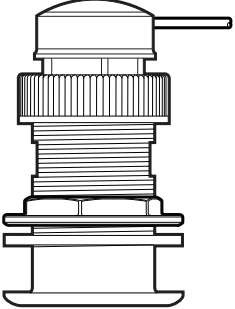
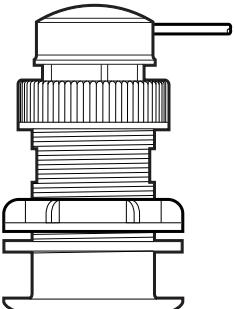
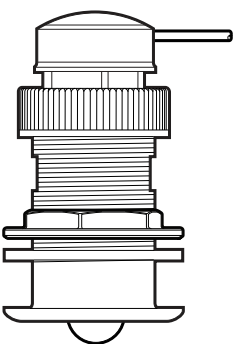
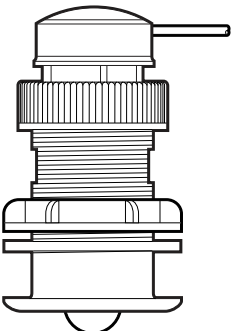
	<p>A22147 — DT800–12 Bronze Thru-Hull</p>
	<p>A80374 — DT800–12 Plastic Thru-Hull (replaces A22112)</p>
	<p>A22146 — DST800 Bronze Thru-Hull</p>
	<p>A80375 — DST800 Plastic Thru-Hull (replaces A22111)</p>

9.3 Instrument Depth, Speed and Temperature (DST) transducers

The DST transducers listed below are compatible with the following instrument displays:

- i40 Depth / i40 Speed / i40 Bidata
- i50 Depth / i50 Speed / i50 Tridata
- i70 / i70s via iTC-5 converter

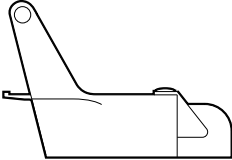
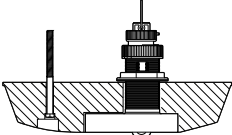
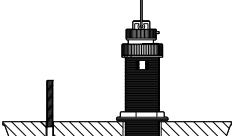
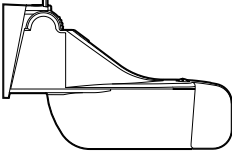
	E26006-PZ — P66 / ST40 Transom mount
	A26043 — B744V (including fairing block) Thru-hull
	A26044 — B744VL (including fairing block) Thru-hull
	E26028-PZ — P66 Transom mount

9.4 Instrument Depth transducers

The depth transducers listed below are compatible with the following instrument displays:

- i40 Depth / i40 Bidata
- i50 Depth / i50 Tridata
- i70 / i70s via iTC-5 converter

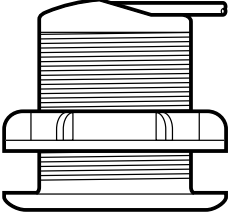
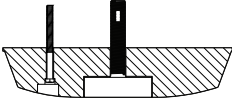
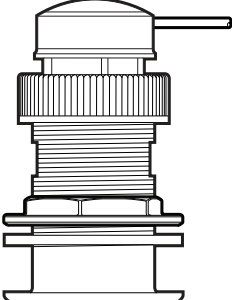
	E26009 — P7 Thru-hull
	E26019-PZ — B45 (including fairing block) Thru-hull
	M78717 — B17 Thru-hull

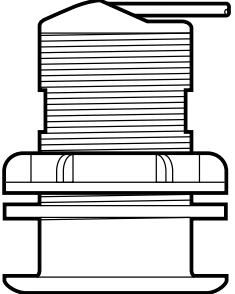
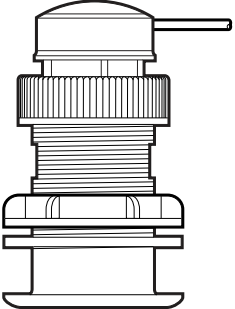
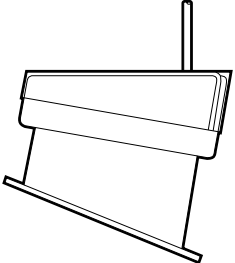
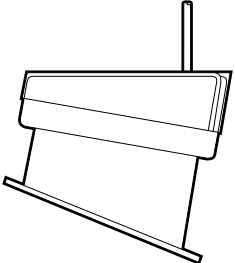
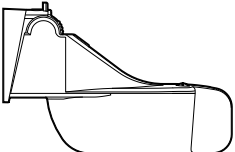
	M78713-PZ — P319 Thru-hull
	E26030 — P17 Thru-hull
	E26001-PZ — P79 In-hull
	A80373 — P79S In-hull T70278 — (includes SeaTalkng [®] adaptor)
	E26027-PZ — P66 Transom mount

9.5 Instrument Speed and Temperature transducers

The speed and temperature transducers listed below are compatible with the following instrument displays:

- i40 Speed / i40 Bidata
- i50 Speed / i50 Tridata
- i70 / i70s via iTC-5 converter

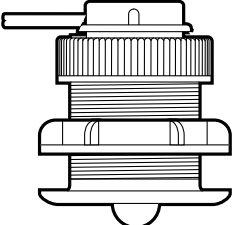
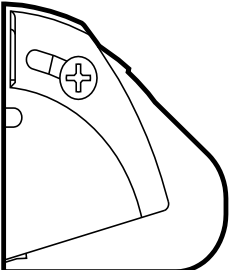
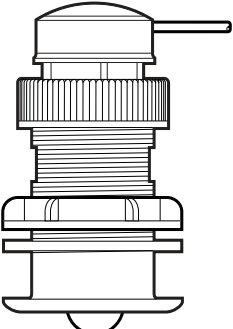
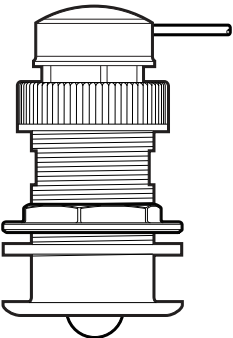
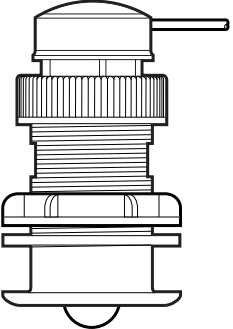
	E26008 — P371 Thru-hull
	E26005 — ST69 Transom mount
	E26031 — P120 / ST800 Thru-hull
	M78716 — B120 Thru-hull
	E25025 — P17 Thru-hull

9.6 Instrument Wind Vane transducer

The wind vane transducers listed below are compatible with the following instrument displays:

- i60 Wind
- i70 / i70s via iTC-5 converter

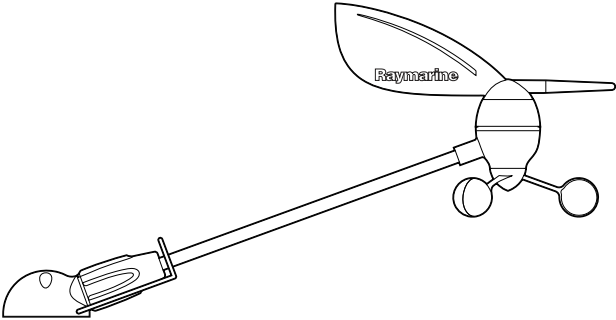
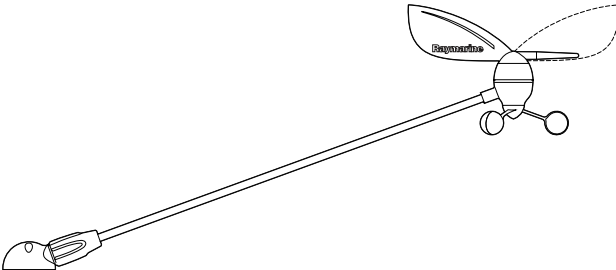
	E22078 — Short arm wind vane
	E22079 — Long arm wind vane

9.7 Instrument Rotavecta transducer

The wind transducers listed below are compatible with the following instrument displays:

- i40 Wind
- i60 Wind
- i70 / i70s via iTC-5 converter

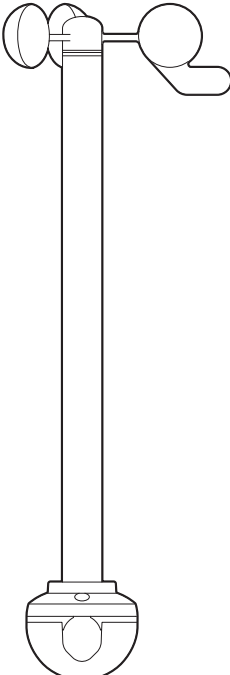
	Z195 — Rotavecta transducer
---	------------------------------------

9.8 Other transducers

When connected using an iTC-5, the transducers listed below are compatible with the your i70 / i70s display:

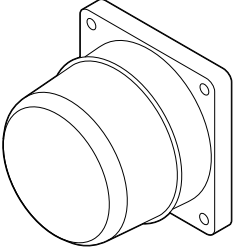
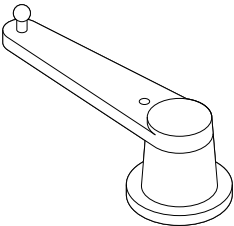
	M81190 — Fluxgate compass
	M81105 — Rudder Reference

9.9 SeaTalkng[®] cables and accessories

SeaTalkng[®] cables and accessories for use with compatible products.

SeaTalkng[®] kits

SeaTalkng kits enable you to create a simple SeaTalkng backbone.

Starter kit (T70134) consists of:

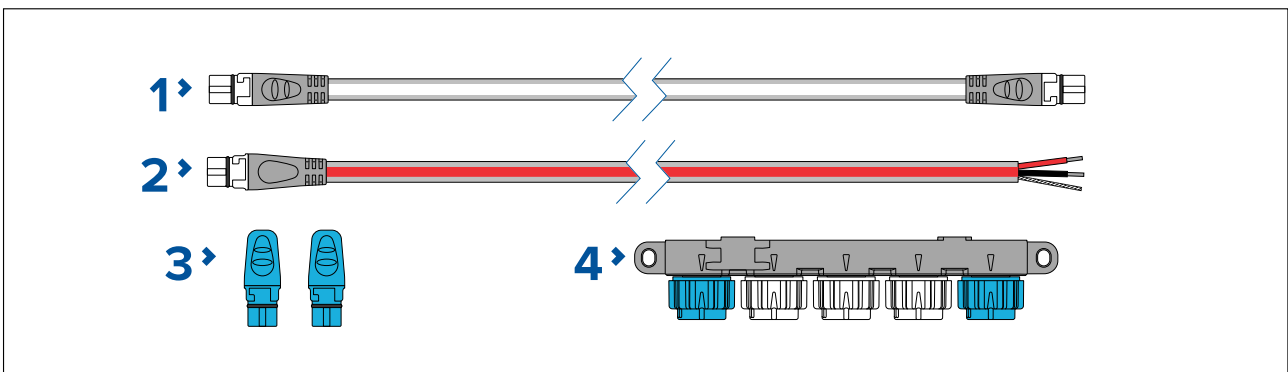

1. 1 x 3 m (9.8 ft) Spur cable (**A06040**). Used to connect device to the SeaTalkng backbone.
2. 1 x 2 m (6.6 ft) Power cable (**A06049**). Used to provide 12 V dc power to the SeaTalkng backbone.
3. 2 x Backbone terminators (**A06031**). Terminators must be fitted to both ends of the SeaTalkng backbone.
4. 1 x 5-Way connector (**A06064**). Each connector block allows connection of up to 3 SeaTalkng devices. Multiple connector blocks can be 'daisy chained' together.

Backbone kit (A25062) consists of:

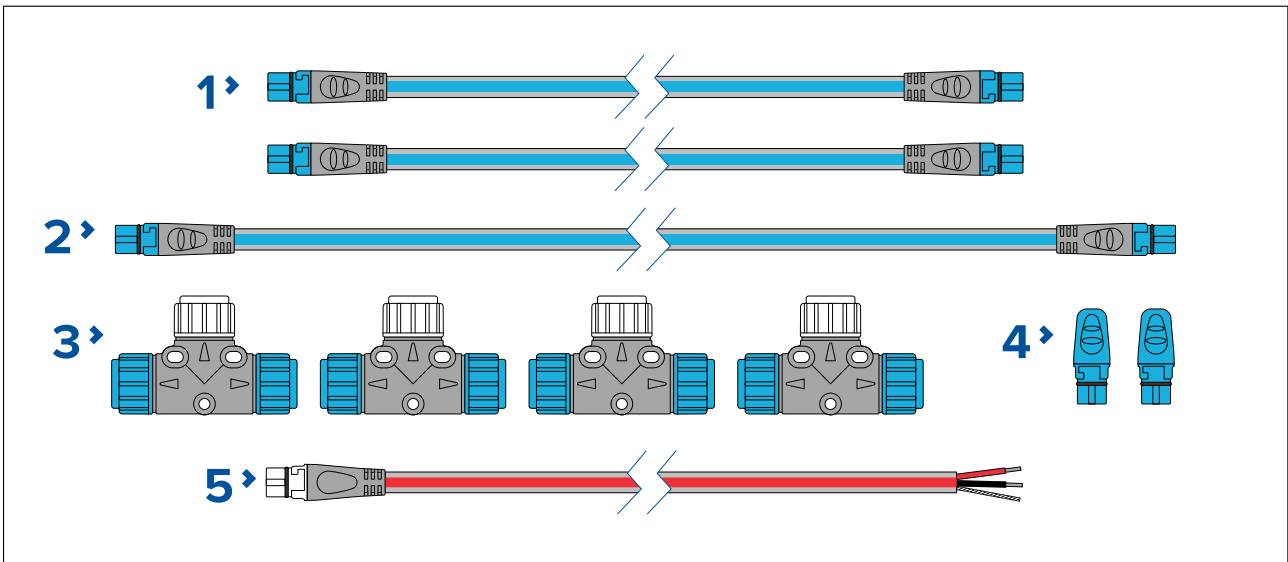

1. 2 x 5 m (16.4 ft) Backbone cables (**A06036**). Used to create and extend the SeaTalkng backbone.
2. 1 x 20 m (65.6 ft) Backbone cable (**A06037**). Used to create and extend the SeaTalkng backbone.
3. 4 x T-piece (**A06028**). Each T-piece allows connection of one SeaTalkng device. Multiple T-pieces can be 'daisy chained' together.
4. 2 x Backbone terminators (**A06031**). Terminators must be fitted to both ends of the SeaTalkng backbone.
5. 1 x 2 m (6.6 ft) Power cable (**A06049**). Used to provide 12 V dc power to the SeaTalkng backbone.

Evolution autopilot cable kit (R70160) consists of:

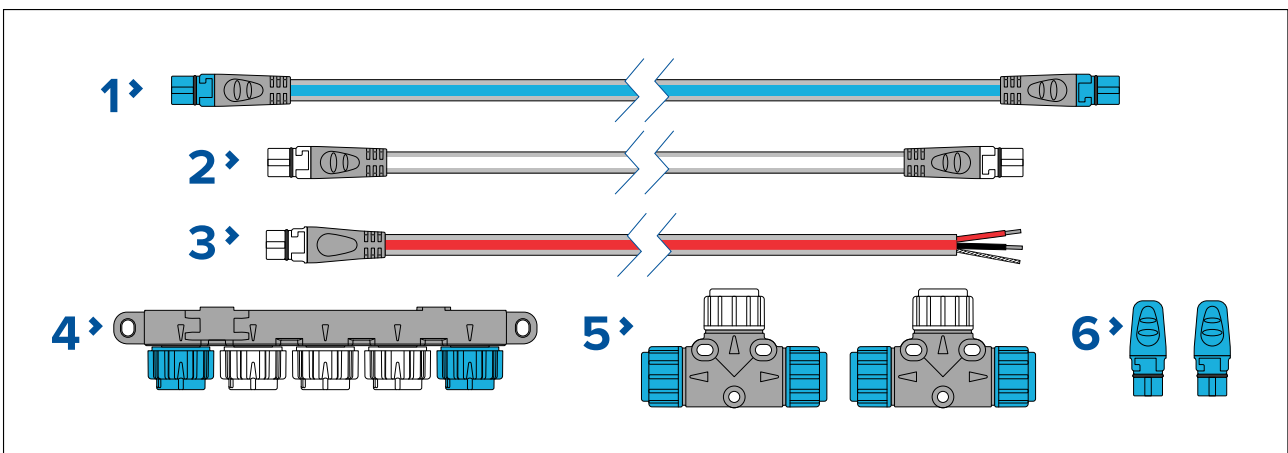

1. 1 x 5 m (16.4 ft) Backbone cable (**A06036**). Used to create and extend the SeaTalkng backbone.
2. 1 x 1 m (3.3 ft) Spur cable (**A06040**). Used to connect device to the SeaTalkng backbone.
3. 1 x 2 m (6.6 ft) Power cable (**A06049**). Used to provide 12 V dc power to the SeaTalkng backbone.
4. 1 x 5-Way connector (**A06064**). Each connector block allows connection of up to 3 SeaTalkng devices. Multiple connector blocks can be 'daisy chained' together.
5. 2 x T-pieces (**A06028**). Each T-piece allows connection of one SeaTalkng device. Multiple T-pieces can be 'daisy chained' together.
6. 2 x Backbone terminators (**A06031**). Terminators must be fitted to both ends of the SeaTalkng backbone.

SeaTalk to SeaTalkng converter kit (E22158) consists of:

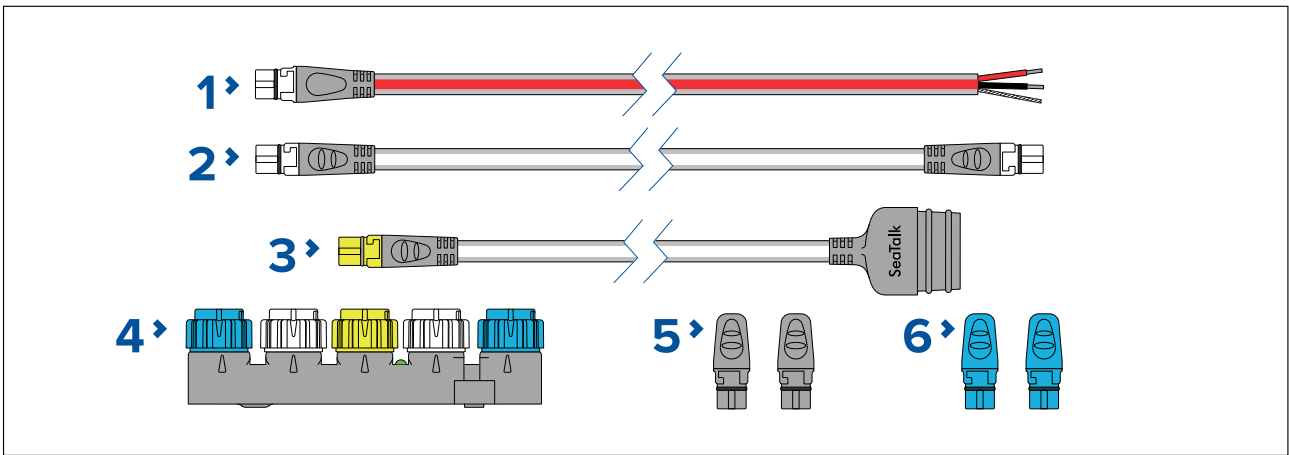

1. 1 x 2 m (6.6 ft) Power cable (**A06049**). Used to provide 12 V dc power to the SeaTalkng backbone.
2. 1 x 1 m (3.3 ft) Spur cable (**A06039**). Used to connect a device to the SeaTalkng backbone.
3. 1 x 0.4 m (1.3 ft) SeaTalk (3 pin) to SeaTalkng adapter cable (**A22164**). Used to connect SeaTalk devices to the SeaTalkng backbone via the SeaTalk to SeaTalkng converter.
4. 1 x SeaTalk to SeaTalkng converter (**E22158**). Each converter allows connection of one SeaTalk device and up to 2 SeaTalkng devices.
5. 2 x Spur blanking plugs (**A06032**). Used to cover unused spur connections in 5–way blocks, T-piece connectors and SeaTalk to SeaTalkng converter.
6. 2 x Backbone terminators (**A06031**). Terminators must be fitted to both ends of the SeaTalkng backbone.

NMEA 0183 VHF 2 wire to SeaTalkng converter kit (E70196) consists of:

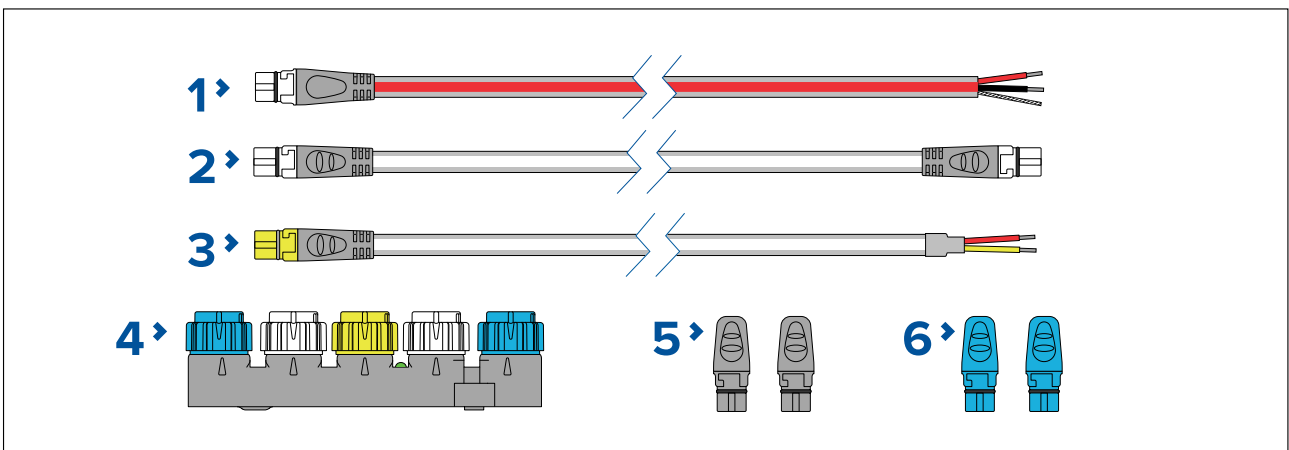

1. 1 x 2 m (6.6 ft) Power cable (**A06049**). Used to provide 12 V dc power to the SeaTalkng backbone.
2. 1 x 1 m (3.3 ft) Spur cable (**A06039**). Used to connect a device to the SeaTalkng backbone.
3. 1 x 1 m (3.3 ft) NMEA 0183 VHF stripped-end (2 wire) to SeaTalkng adapter cable (**A06071**). Used to connect an NMEA 0183 VHF radio to the SeaTalkng backbone via the NMEA 0183 VHF to SeaTalkng converter.
4. 1 x SeaTalk to SeaTalkng converter (**E22158**). Each converter allows connection of 1 SeaTalk device and up to 2 SeaTalkng devices.
5. 2 x Spur blanking plugs (**A06032**). Used to cover unused spur connections in 5-way blocks, T-piece connectors and SeaTalk to SeaTalkng converter.
6. 2 x Backbone terminators (**A06031**). Terminators must be fitted to both ends of the SeaTalkng backbone.

SeaTalkng[®] spur cables

SeaTalkng spur cables are required to connect devices to the SeaTalkng backbone.

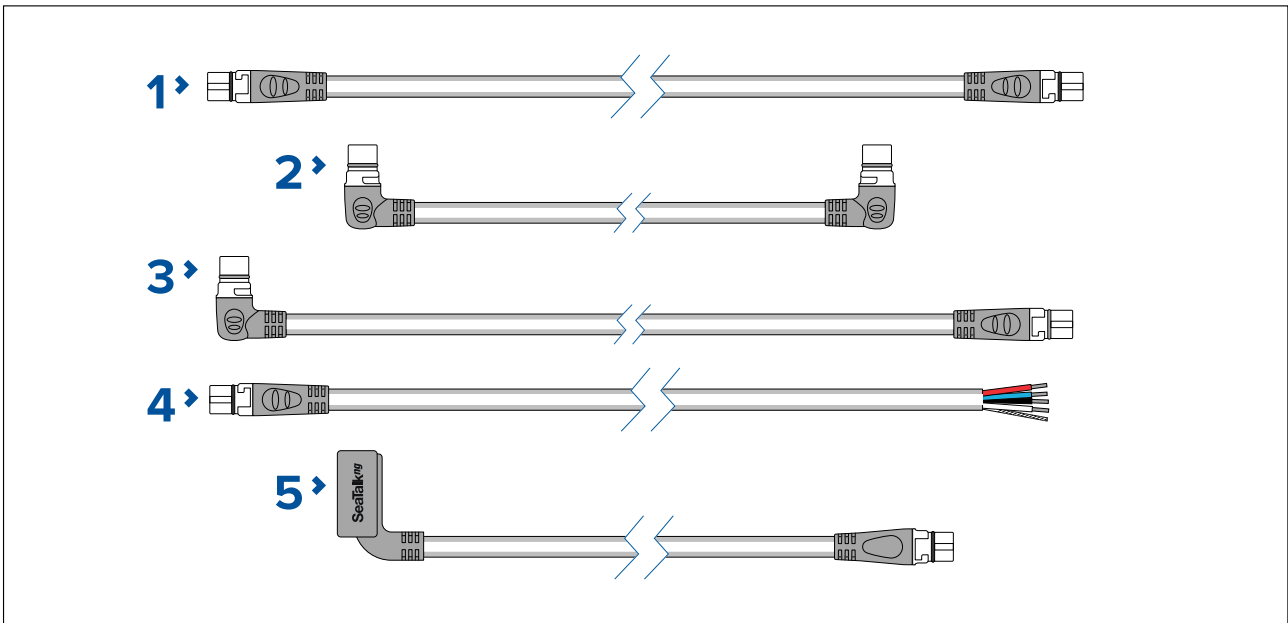

1. SeaTalkng spur cables:
 - 0.4 m (1.3 ft) Spur cable (**A06038**).
 - 1 m (3.3 ft) Spur cable (**A06039**).
 - 3 m (9.8 ft) Spur cable (**A06040**).
 - 5 m (16.4 ft) Spur cable (**A06041**).
2. 0.4 m (1.3 ft) Elbow (right angled) to elbow spur cable (**A06042**). Used in confined spaces where a straight spur cable will not fit.
3. 1 m (3.3 ft) Elbow (right angled) to straight spur cable (**A06081**). Used in confined spaces where a straight spur cable will not fit.
4. SeaTalkng to stripped-end spur cables (Connects compatible product that do not have a SeaTalkng connector such as transducer pods):
 - 1 m (3.3 ft) SeaTalkng to stripped-end spur cable — **A06043**
 - 3 m (9.8 ft) SeaTalkng to stripped-end spur cable — **A06044**
5. 0.3 m (1.0 ft) ACU / SPX autopilot to SeaTalkng spur cable (**R12112**). Connects the course computer to the SeaTalkng backbone. This connection can also be used to provide 12 V dc power to the SeaTalkng backbone.

SeaTalkng® backbone cables

SeaTalkng backbone cables are used to create or extend a SeaTalkng backbone.

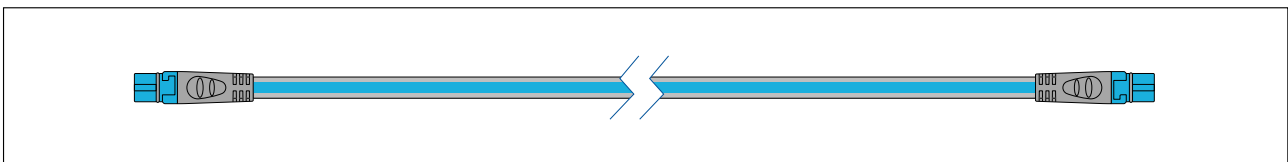

- 0.4 m (1.3 ft) Backbone cable (**A06033**).
- 1 m (3.3 ft) Backbone cable (**A06034**).
- 3 m (9.8 ft) Backbone cable (**A06035**).
- 5 m (16.4 ft) Backbone cable (**A06036**).
- 9 m (29.5 ft) Backbone cable (**A06068**).
- 20 m (65.6 ft) Backbone cable (**A06037**).

SeaTalkng® power cables

SeaTalkng power cables are used to provide the SeaTalkng backbone with a single 12 V dc power source. The power connection must include a 5 amp inline fuse (not supplied).

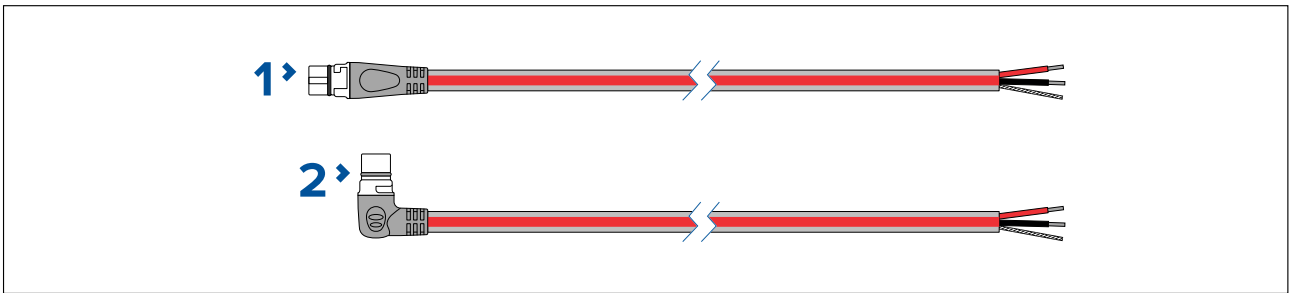

1. 2 m (6.6 ft) Power cable (straight) **(A06049)**.
2. 2 m (6.6 ft) Elbow (right angled) power cable **(A06070)**.

SeaTalkng® connectors

SeaTalkng connectors are used to connect SeaTalkng devices to the SeaTalkng backbone and to create and extend the backbone.

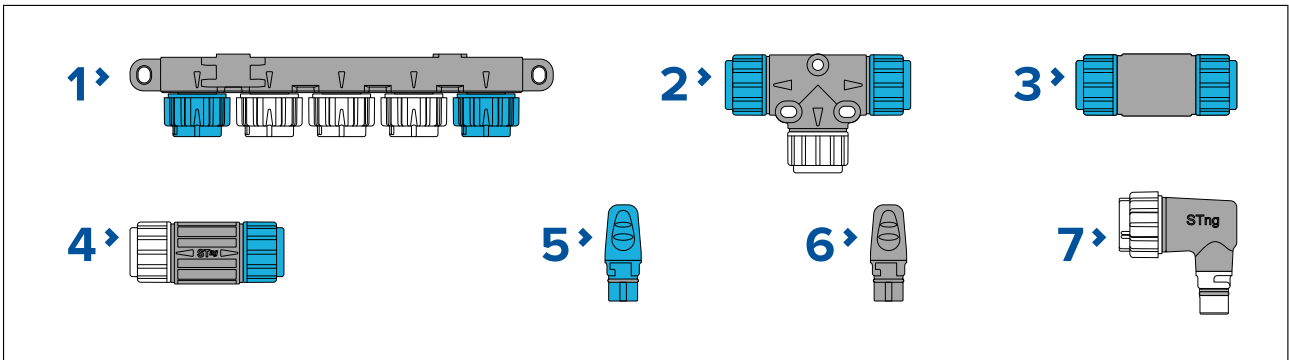

1. 5-Way connector **(A06064)**. Each connector block allows connection of up to 3 SeaTalkng devices. Multiple connector blocks can be 'daisy chained' together.
2. T-piece **(A06028)**. Each T-piece allows connection of one SeaTalkng device. Multiple T-pieces can be 'daisy chained' together.
3. Backbone extender **(A06030)**. Used to connect 2 backbone cables together.
4. Inline terminator **(A80001)**. Used to connect a spur cable and SeaTalkng device at the end of a backbone instead of a backbone terminator.
5. Backbone terminator **(A06031)**. Terminators must be fitted to both ends of the SeaTalkng backbone.
6. Spur blanking plugs **(A06032)**. Used to cover unused spur connections in 5-way blocks, T-piece connectors, or the SeaTalk to SeaTalkng converter.
7. Spur connector right angled elbow **(A06077)**. Used in confined spaces where a straight spur cable will not fit.

SeaTalkng® adaptors and adaptor cables

SeaTalkng adaptor cables are used to connect devices designed for different CAN bus backbones (e.g.: SeaTalk or DeviceNet) to the SeaTalkng backbone.

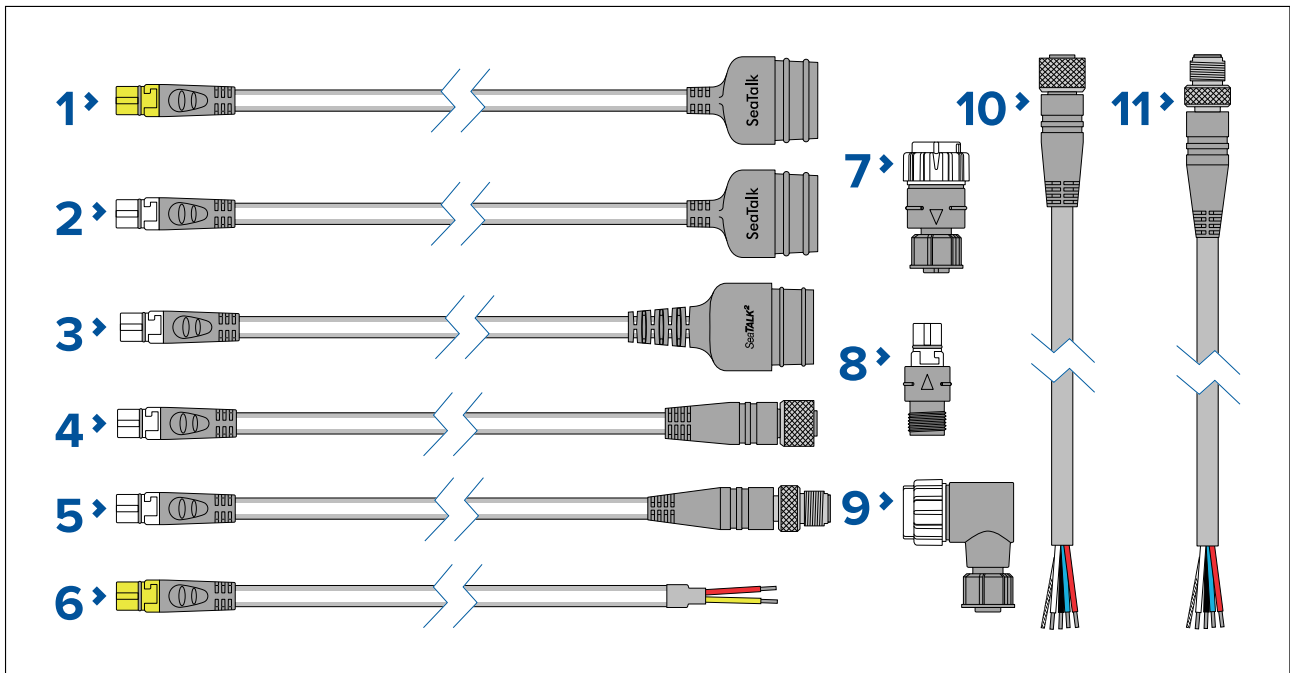

1. 1 m (3.3 ft) SeaTalk (3 pin) to SeaTalkng converter cable (**A22164 / A06073**). Can be used to connect a SeaTalk device to a SeaTalkng backbone via the SeaTalk to SeaTalkng converter, or to connect a SeaTalkng product directly to a SeaTalk network.
2. 0.4 m (1.3 ft) SeaTalk (3 pin) to SeaTalkng adaptor cable (**A06047**). Can be used to connect a SeaTalk device to a SeaTalkng backbone via the SeaTalk to SeaTalkng converter, or to connect a SeaTalkng product directly to a SeaTalk network.
3. 0.4 m (1.3 ft) SeaTalk2 (5 pin) to SeaTalkng adaptor cable (**A06048**). Used to connect SeaTalk2 devices or networks to a SeaTalkng backbone.
4. SeaTalkng to DeviceNet (female) adaptor cables connect NMEA 2000 devices that use a DeviceNet connector to the SeaTalkng backbone, or connects SeaTalkng devices to an NMEA 2000 network. The following cables are available:
 - 0.4 m (1.3 ft) SeaTalkng to DeviceNet (female) adaptor cable (**A06045**).
 - 1 m (3.3 ft) SeaTalkng to DeviceNet (female) adaptor cable (**A06075**).
5. SeaTalkng to DeviceNet (male) adaptor cables. Connect NMEA 2000 devices that use a DeviceNet connector to the SeaTalkng backbone, or connect SeaTalkng devices to an NMEA 2000 network. The following cables are available:
 - 0.1 m (0.33 ft) SeaTalkng to DeviceNet (male) adaptor cable (**A06078**).
 - 0.4 m (1.3 ft) SeaTalkng to DeviceNet (male) adaptor cable (**A06074**).
 - 1 m (3.3 ft) SeaTalkng to DeviceNet (male) adaptor cable (**A06076**).
 - 1.5 m (4.92 ft) SeaTalkng to DeviceNet (male) adaptor cable (**A06046**).
6. 1 m (3.3 ft) NMEA 0183 VHF stripped-end (2 wire) to SeaTalkng adapter cable (**A06071**). Used to connect an NMEA 0183 VHF radio to the SeaTalkng backbone via the NMEA 0183 VHF to SeaTalkng converter.
7. SeaTalkng (male) to DeviceNet (female) adaptor (**A06082**).
8. SeaTalkng (female) to DeviceNet (male) adaptor (**A06083**).
9. SeaTalkng (male) to DeviceNet (female) elbow (right angled) adaptor (**A06084**).
10. (0.4 m (1.3 ft) DeviceNet (female) to stripped-end adaptor cable (**E05026**).
11. (0.4 m (1.3 ft) DeviceNet (male) to stripped-end adaptor cable (**E05027**).

Appendix A Supported NMEA 2000 PGN list

Administration PGNs

- **59392** — ISO Acknowledge (Receive / Transmit)
- **59904** — ISO Request (Receive / Transmit)
- **60928** — ISO Address Claim (Receive / Transmit)
- **126208** — NMEA — Request, Commanded, Acknowledged Group Function (Receive / Transmit)
- **126464** — PGN Transmit and Receive List (Receive / Transmit)
- **126996** — Product Information (Receive / Transmit)

Raymarine® provides field programmability of the Device and System Instances within PGN 60928 which can be commanded via use of PGN 126208 as required by the latest **NMEA 2000** standard.

Data PGNs

- **127237** — Heading/Track Control (Receive)
- **127245** — Rudder (Receive / Transmit)
- **127250** — Vessel Heading (Receive / Transmit)
- **127251** — Rate of Turn (Receive / Transmit)
- **127257** — Attitude (Receive)
- **127258** — Magnetic Variation (Receive / Transmit)
- **127488** — Engine Parameters, Rapid Update (Receive)
- **127489** — Engine Parameters, Dynamic (Receive)
- **127493** — Transmission Parameters, Dynamic (Receive) **In software version 3.20 onwards**, the following warnings are supported:
 - Check Transmission
 - Over Temperature
 - Low Oil Pressure
 - Low Oil Level
 - Sail Drive
- **127496** — Trip Parameters, Vessel (Receive)
- **127497** — Trip Parameters, Engine (Receive)
- **127498** — Engine Parameters, Static (Receive)
- **127505** — Fluid Level (Receive)
- **127508** — Battery status (Receive)
- **128259** — Speed, (Receive / Transmit)
- **128267** — Water Depth (Receive / Transmit)
- **128275** — Distance Log (Receive / Transmit)
- **129025** — Position, Rapid Update (Receive / Transmit)
- **129026** — COG & SOG, Rapid Update (Receive / Transmit)
- **129029** — GNSS Position Data (Receive / Transmit)
- **129033** — Time & Date (Receive / Transmit)
- **129038** — AIS Class A Position Report (Receive)
- **129039** — AIS Class B Position Report (Receive)
- **129040** — AIS Class B Extended Position Report (Receive)
- **129041** — AIS Aids to Navigation (AtoN) Report (Receive)
- **129044** — Datum (Receive / Transmit)
- **129283** — Cross Track Error (Receive / Transmit)
- **129284** — Navigation Data (Receive / Transmit)
- **129291** — Set & Drift, Rapid Update (Receive)
- **129801** — AIS Addressed Safety Related Message (Receive)
- **129802** — AIS Safety Related Broadcast Message (Receive)
- **129809** — AIS Class B "CS" Static Report, Part A (Receive)

- **129810** — AIS Class B "CS" Static Report, Part B (Receive)
- **130306** — Wind Data (Receive / Transmit)
- **130310** — Environmental Parameters (Receive / Transmit)
- **130311** — Environmental Parameters (Receive / Transmit)
- **130576** — Small Craft Status (Receive)
- **130577** — Direction Data (Receive)

Index

A

Accessories	
SeaTalkng adaptor cables	67
SeaTalkng backbone cables	66
SeaTalkng cables	63
SeaTalkng connectors	67
SeaTalkng kits	63
SeaTalkng Power cables	66
SeaTalkng spur cables	65

B

Bezel removal.....	24
Buttonpad removal.....	25
Buttons	15

C

Cable	
Bend radius.....	30
Protection	30
Routing	30
Security.....	30
Strain relief.....	30
Cleaning	44
Screen.....	44
Cleaning the transducer	44
Compass safe distance	23
Connecting SeaTalkng cables.....	31
Connections	
Battery	35
Distribution panel.....	35
Overview.....	31
Power.....	32–34
SeaTalkng	31
SeaTalkng power cable	34
Transducers	38
Contact details.....	52
Controls	15

D

Distribution panel connection	35
Documentation	
Installation instructions	14
Mounting template.....	14
Operation instructions	14

E

Electromagnetic Compatibility.....	22
EMC, See Electromagnetic Compatibility	
Expanded system	19

F

Fuse rating, SeaTalkng®	33
-------------------------------	----

I

Interference	23
--------------------	----

See also Compass safe distance	
iTC-5 connection	38

L

Location requirements	23
Viewing angle	23

M

Maintenance.....	44
Mounting	26

N

NMEA 2000.....	69
LEN	31
NMEA 2000 connection.....	37
NMEA 2000 LEN	32

O

Operation instructions	14
------------------------------	----

P

Parts supplied.....	16
PGNs	69
Power	
Battery connection.....	35
Distribution	34
Distribution panel.....	35
SeaTalkng power cable	34
Sharing a breaker	35
Power cable extension	36
Power troubleshooting.....	48
Product dimensions.....	24
Product loading	31
Product overview.....	15
Product recycling (WEEE)	10
Product support.....	52

R

Refitting buttonpad.....	27
Routine checks.....	44

S

SeaTalk	38
SeaTalkng	
Adaptor cables	67
Backbone cables	66
Backbone length.....	33
Connecting	31
Connecting cables.....	31
Connectors	67
Kits	63
Legacy transducer pod connection	39
LEN	31–32
Load equivalency number	31–32
Power.....	32–33
Power cables	66

Spur cables	65
System loading	33
SeaTalkng cables	63
Service Center.....	52
Servicing.....	44
Software updates	17–18
Spade terminals.....	40
Suppression ferrite fitting	32
System examples	18

T

Technical specification	55
Technical support.....	52
Thermal breaker rating, SeaTalkng®	33
Tools required	22
Transducer pod	39
Troubleshooting	48

U

Upgrading, See Software updates

W

Warranty	52
WEEE Directive.....	10



Raymarine

Marine House, Cartwright Drive, Fareham, Hampshire.
PO15 5RJ. United Kingdom.

Tel: +44 (0)1329 246 700

www.raymarine.com

Raymarine®

a brand by  **FLIR®**